

## Stockholm Chevron Bed Frame

Double/King

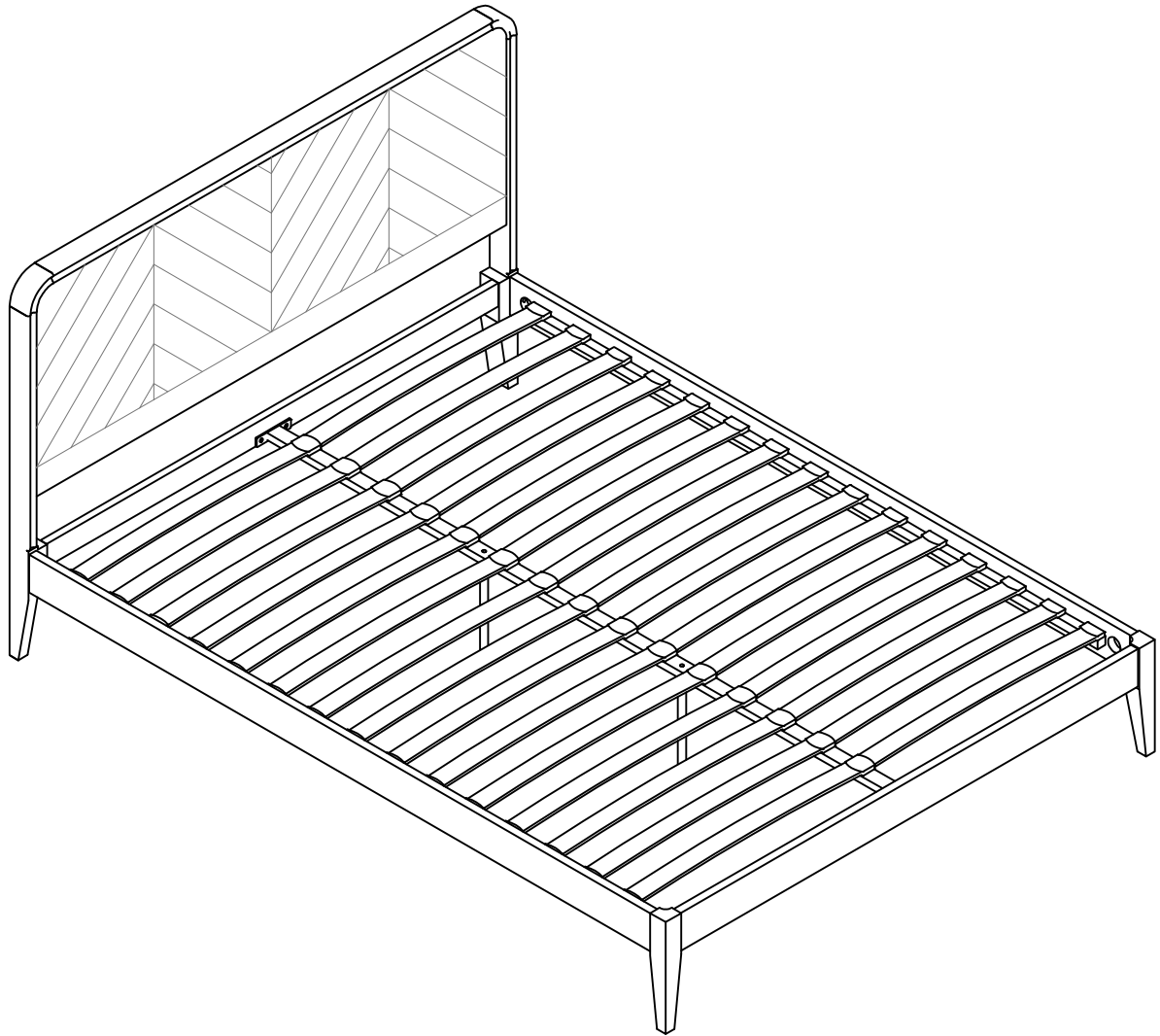

Up to 2 hours  
assembly time

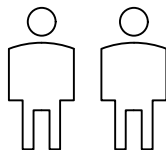

Two person  
assembly

V1.0

## Important

### **Assembly Tip**

Before you begin, it's best to identify all of the parts and fittings to build your bed frame. We advise laying these out on the floor to check you have everything, and to familiarise yourself with all of the parts and fittings before building.

### **Top Tip**

We recommend that you build your new bed frame in the room you'd like it to be located. This will help prevent any risk of damage to the frame whilst moving it.

### **Safety and Care**

It's important to ensure children and animals are kept away from the assembly area, as there are small components used in this bed frame which could present a choking hazard. All plastic and wrapping materials should also be kept away from children and animals to prevent any risk of suffocation.

### **Help and Support**

Please contact our customer service team on 0113 519 0311 if you have any questions or issues with your purchase.

### **Recycling**

Please ensure that packaging is disposed of in a safe and environmentally friendly way, and recycle where possible. Please keep your assembly instructions safe to refer back to in the future

## Parts

Before you begin building your bed frame, Please take a moment to read through the instructions and make sure that you have all the relevant parts listed on the parts check list.

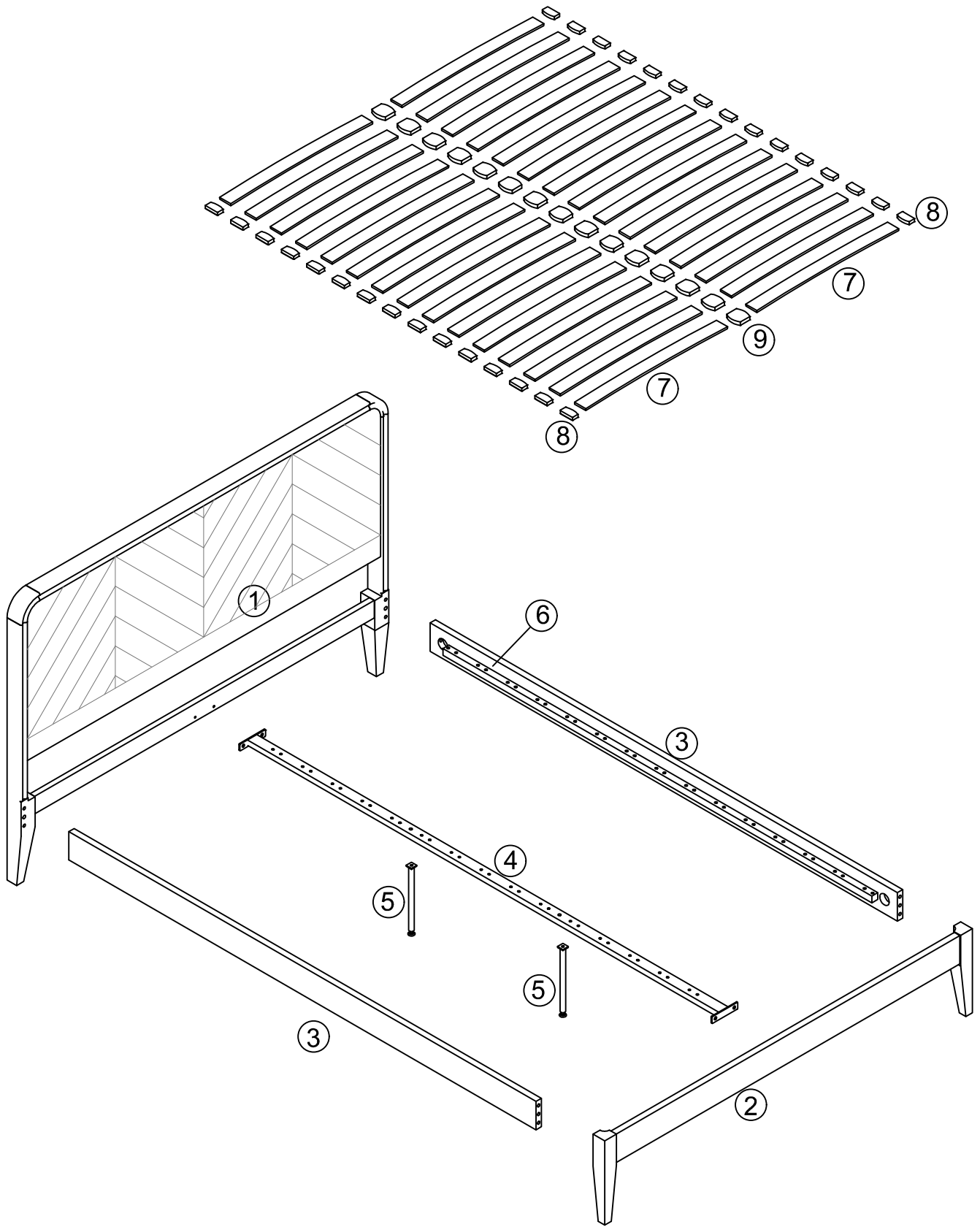

## Parts Check List









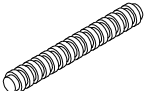

NO.	Parts List	Qty	Box No
1	Headboard	1pc	Box 1
2	Footboard	1pc	Box 1
3	Side Rail	2pcs	Box 2
4	Central Support Rail	1pc	Box 2

NO.	Parts List	Qty	Box No
5	Support Leg	2pcs	Box 1
7	Slat Double/king	26/30pcs	Box 1
8	Side Slat Cap Double/king	26/30pcs +1 extra	Box 1
9	Centre Slat Cap Double/king	13/15pcs +1 extra	Box 1

## Pre-assembled Parts Check List

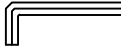
6	Side Support Rail	2pcs	Box 2
---	-------------------	------	-------

## Fittings

 (A) Connector 4pcs	 (B) M8 74mm Connecting bolt 4pcs	 (C) M8 Nut 4pcs	 (D) Ø8 Spring washer 4pcs
 (E) Ø10 40mm Wood Dowel 8pcs+1 extra	 (F) M6 15mm Bolt 4pcs	 (G) M4 Allen key 1pc	 (H) M5 Allen key 1pc
 (I) Spanner 1pc	 (J) M8 35mm Bolt 2pcs (Already inserted into support legs)	 (K) Ø40 Plastic Cap 4pcs	

## Pre - assembled Fitting

 (L) M6 40 Bolt 10pcs
---

## Step 1: Attaching the Bolt & Wood Dowel to the Headboard & Footboard

B  4pcs

E  8pcs

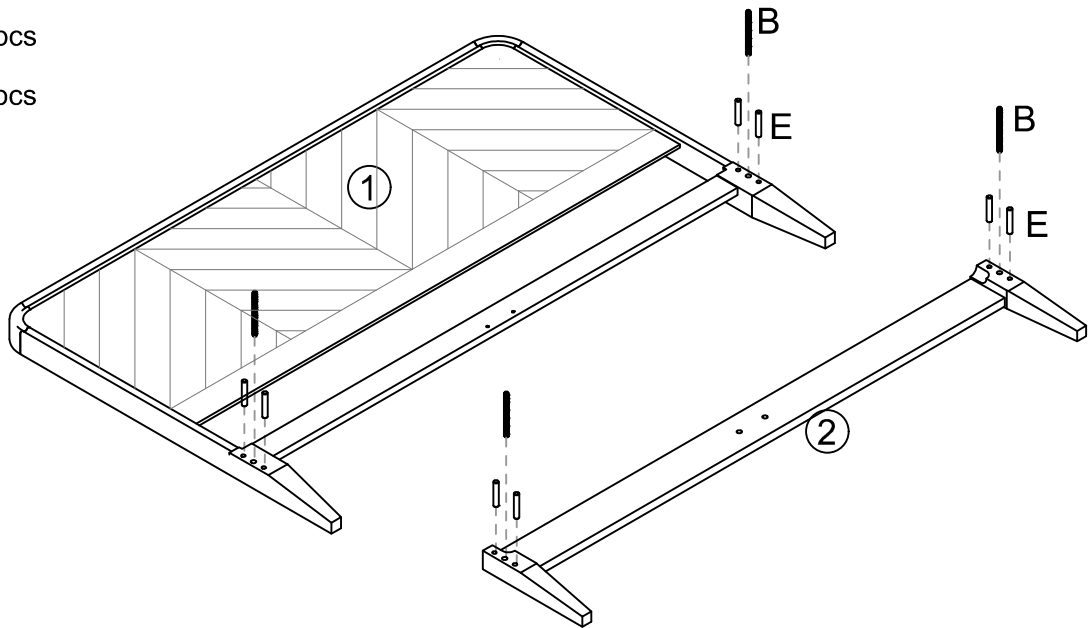

## Step 2: Attaching the Side Rails to the Headboard & Footboard

A  4pcs

C  4pcs

D  4pcs

I  1pc

K  4pcs

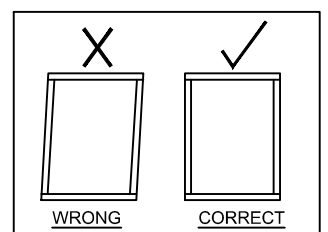
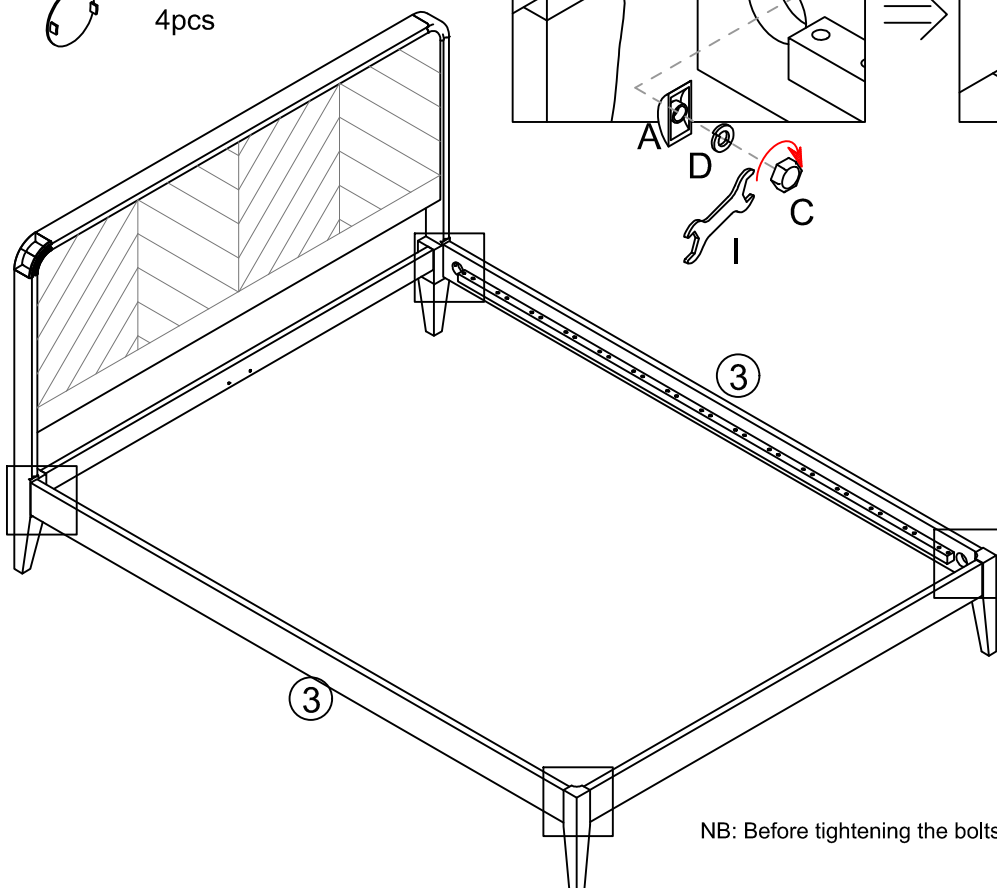
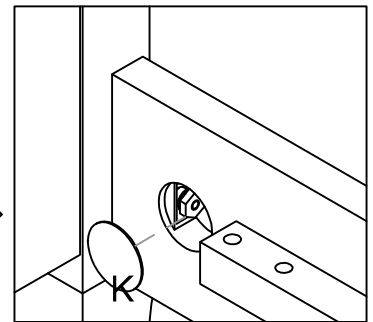
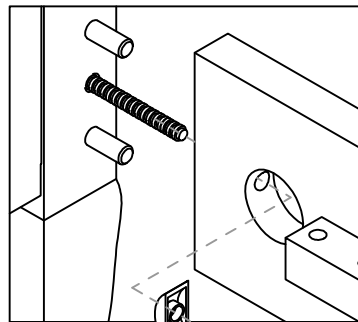

NB: Before tightening the bolts, please ensure the bed frame is square

### Step 3: Attaching the Support Leg to the Central support Rail

J  2pcs (Already inserted into support legs)

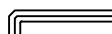
H  1pc

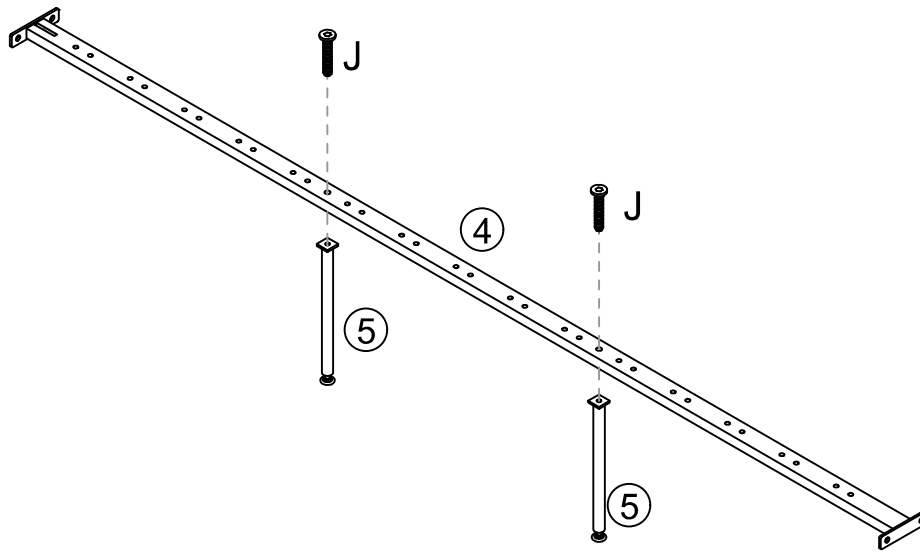



### Step 4: Attaching the Central Support Rail to the Headboard &Footboard

F  4pcs

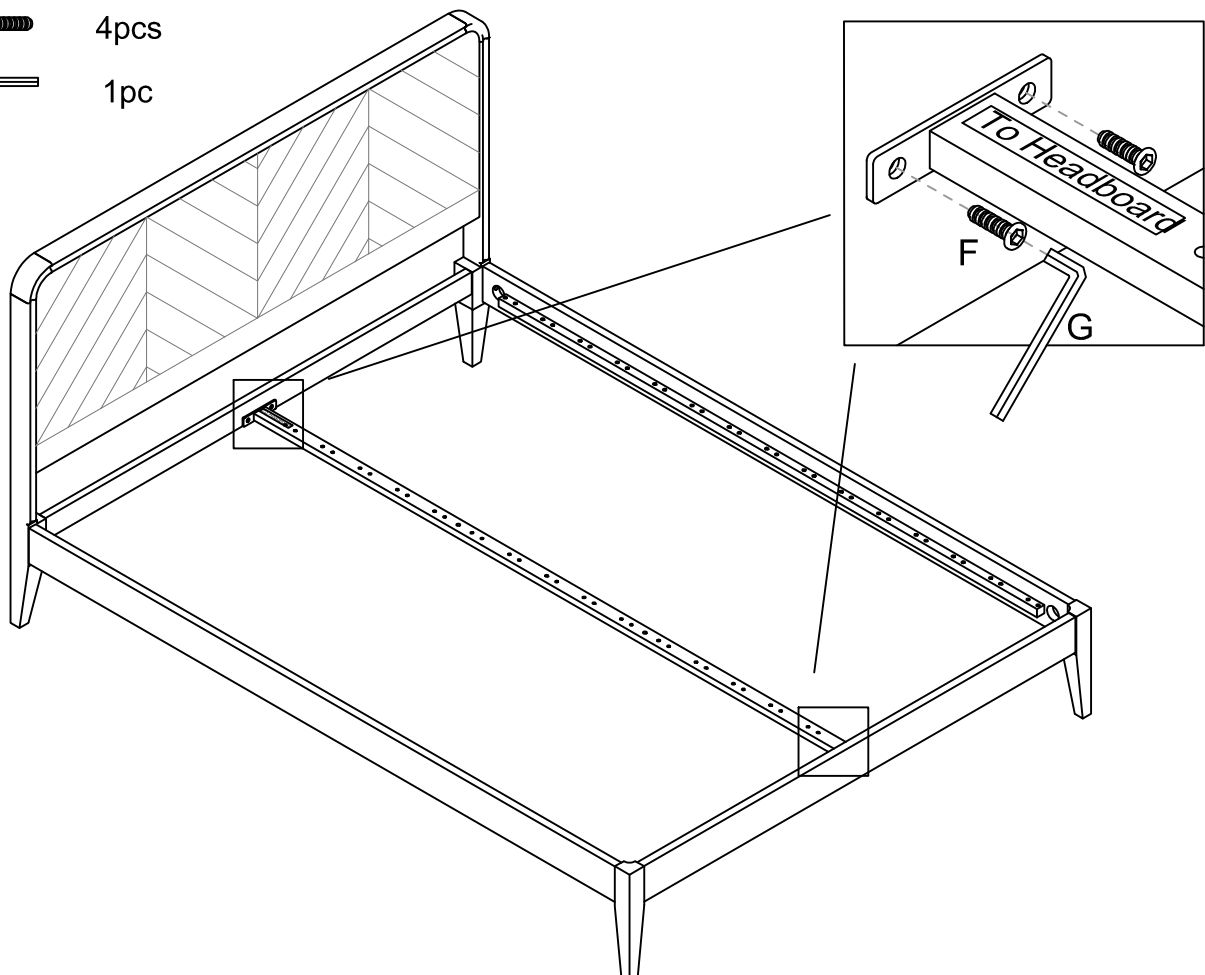
G  1pc



## Step 5: Attaching the Slat Caps & Slats to the Bed Frame

- 8  Side Slat Cap Double/king 26/30 pcs
- 9  Centre Slat Cap Double/king 13/15 pcs

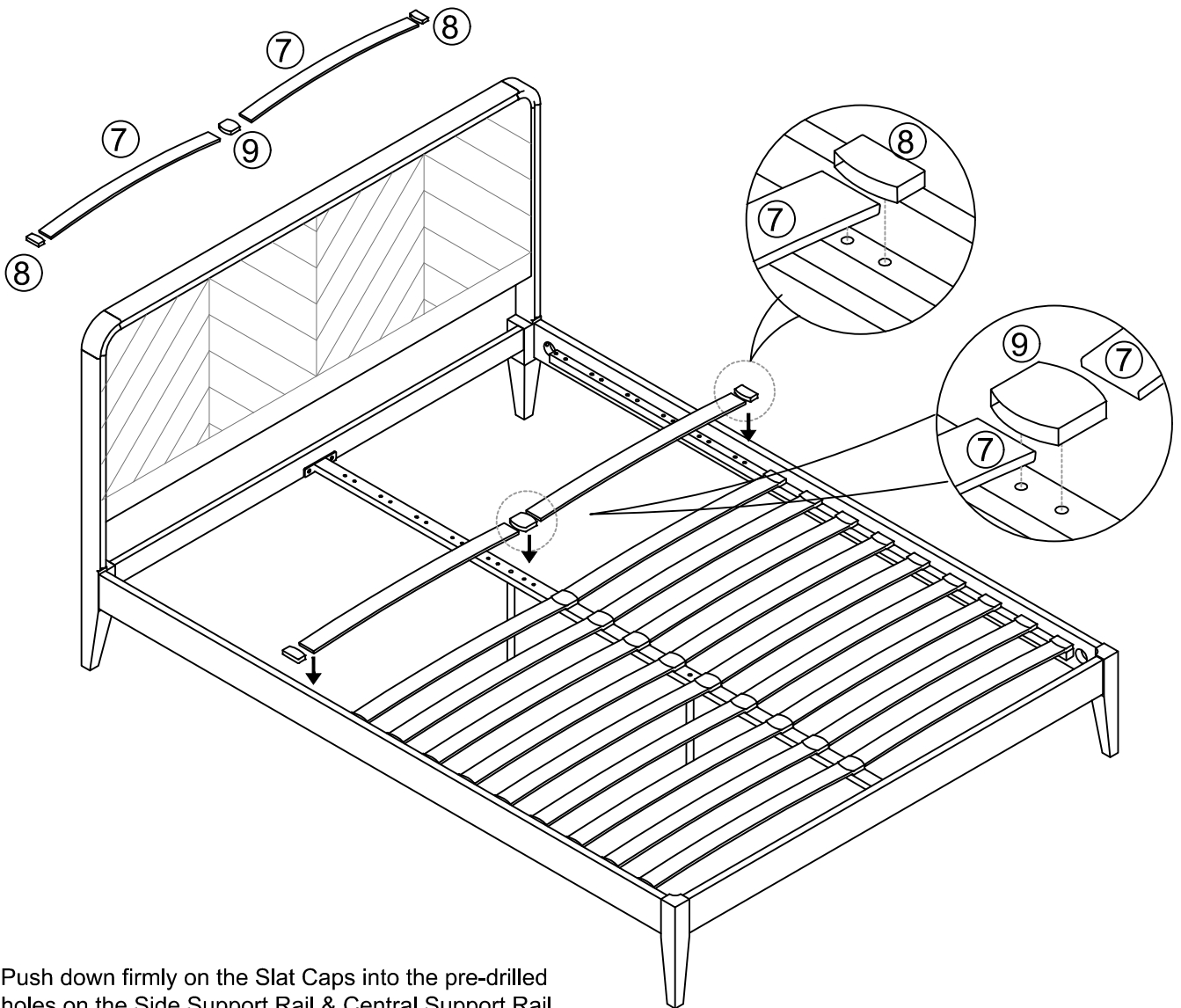

Push down firmly on the Slat Caps into the pre-drilled holes on the Side Support Rail & Central Support Rail. It is recommended to push the Centre Slat Caps into position before pushing down on the Side Slat Caps.

# Care and Maintenance

Here are some good tips to keep your new bed frame in tip-top condition.

## Cleaning

To clean your new bed frame, we advise using a damp cloth if the fabric is dusty or a low suction vacuum. Do not use abrasive chemicals or bleach as this may damage the product.

## Checking and Moving

Periodically, we recommend you check that the screws and fixtures haven't become loose over time. To move your bed frame, we recommend lifting it where possible, as dragging or pushing it could cause damage to the legs or flooring.

## Fabric

Please note, depending on the lighting, positioning and surroundings of your room, the shade of the fabric will appear differently. Over a period of time, the fabric may also lighten or fade slightly due to light exposure.