

# DUSK.COM

LIVING | BEDROOM | DINING

Range Name: Sienna

Product Dimensions: L100xW50xH45 (cm)

## Coffee Table

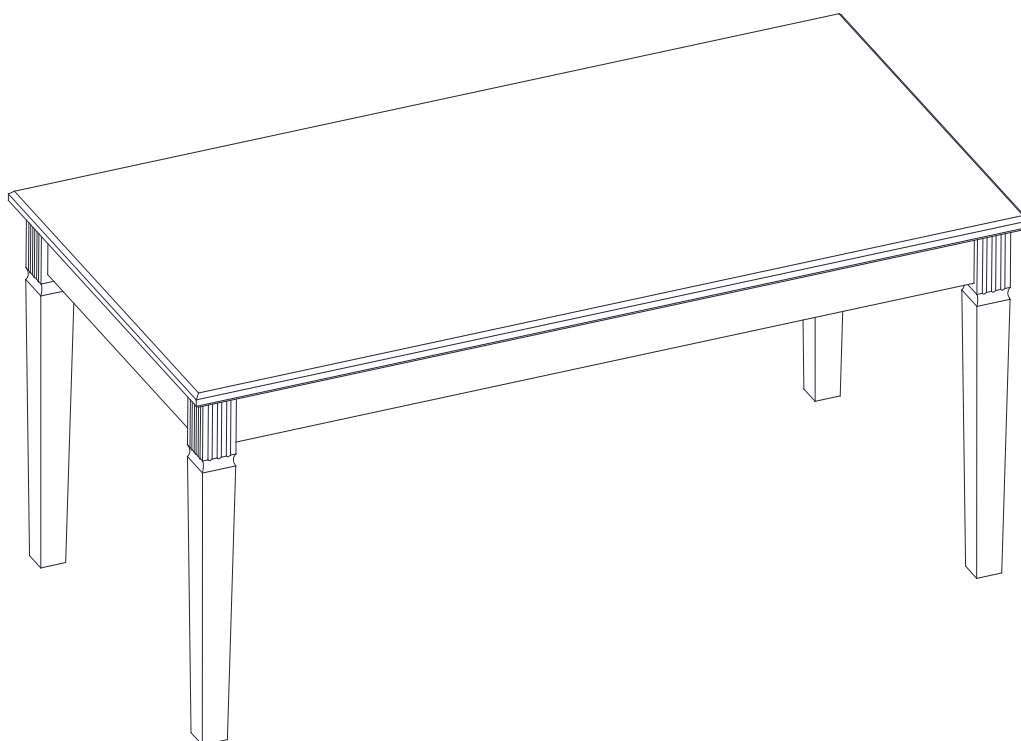

THIS INSTRUCTION BOOKLET CONTAINS IMPORTANT SAFETY INFORMATION.  
PLEASE READ AND KEEP FOR FUTURE REFERENCE.

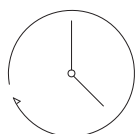

Up to 40 minutes  
assembly time

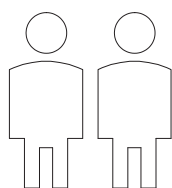

Two person  
assembly

This product is intended for domestic use only, not for commercial purposes.

P-1/6

# IMPORTANT

## ASSEMBLY TIP

Before you begin, it's best to identify all of the parts and fittings to build your coffee table frame. We advise laying these out on the floor to check you have everything, and to familiarise yourself with all of the parts and fittings before building.

## TOP TIP

We recommend that you assemble the coffee table in the room you'd like it to be located. This will help prevent any risk of damage to the frame whilst moving it.

## SAFETY AND CARE

1. It's important to ensure children and animals are kept away from the assembly area, as there are small components used in this product which could present a choking hazard. All plastic and wrapping materials should also be kept away from children and animals to prevent any risk of suffocation.
2. Do not stand on your product.
3. Always use the item on firm level ground, ensuring all legs remain in contact with the ground.
4. Place heaviest items in the lowest drawers.
5. Do not set TV or other heavy objects on top of the product.
6. Children should always be under supervision whilst using this product. Never allow children to climb on the drawers.
7. Never keep more than one drawer open at the same time.
8. In order to prevent overturning, this product must be used with the wall attachment device provided.
9. Serious or fatal crushing injuries can occur from tipping furniture.

## HELP AND SUPPORT

Please contact our customer service team on 0113 519 0311 if you have any questions or issues with your purchase.

## RECYCLING

Please ensure that packaging is disposed of in a safe and environmentally friendly way, and recycle where possible. Please keep your assembly instructions safe to refer back to in the future.

## CARE AND MAINTENANCE

1. Only clean using a damp cloth, do not use bleach or abrasive cleaners as they may damage the finish over time.
2. Do not use a very wet cloth or allow any liquid to contact with the surface for a long period of time. Wipe any spillage immediately. Absorption can cause wood to warp or finishes to de-laminate.
3. Do not scrub or rub the surface when cleaning.
4. Do not drag the coffee table when moving, lift it off the floor instead.
5. Use a placemat or a coaster when putting hot items (e.g. hot drinks and dishes) on the wood surface.
6. It is not recommended to place the item next to sources of heat such as radiators, fires or directly exposed to sunlight. This may cause the wood to crack, split or fade due to the heat and humidity.
7. Wood will mellow and change colour over time, we recommend that ornaments and items placed on the surface to be moved regularly to prevent uneven mellowing.
8. Regularly check all fixings to ensure none have come loose. Re-tighten if necessary.
9. Avoid sharp items such as a screwdriver or any pointy tools.

# Parts list





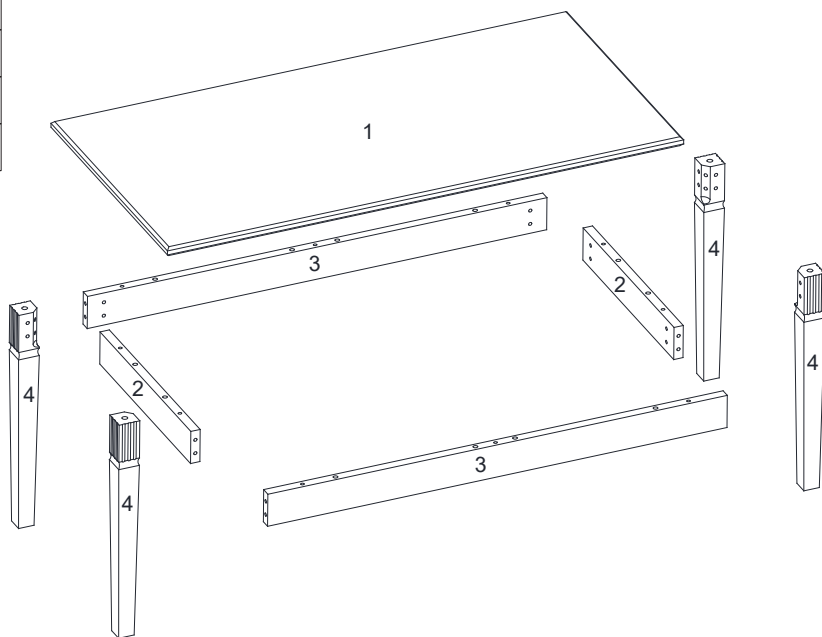

Before you begin building your coffee table, please take a moment to read through the instructions and make sure that you have all the relevant parts listed on the parts check list.

Part Number	Part Description	Quantity
1	Top Panel	1 pc
2	Short Support Bar	2 pcs
3	Long Support Bar	2 pcs
4	Leg	4 pcs





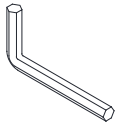

## Fittings

Please check you have all the fittings listed below with your product.

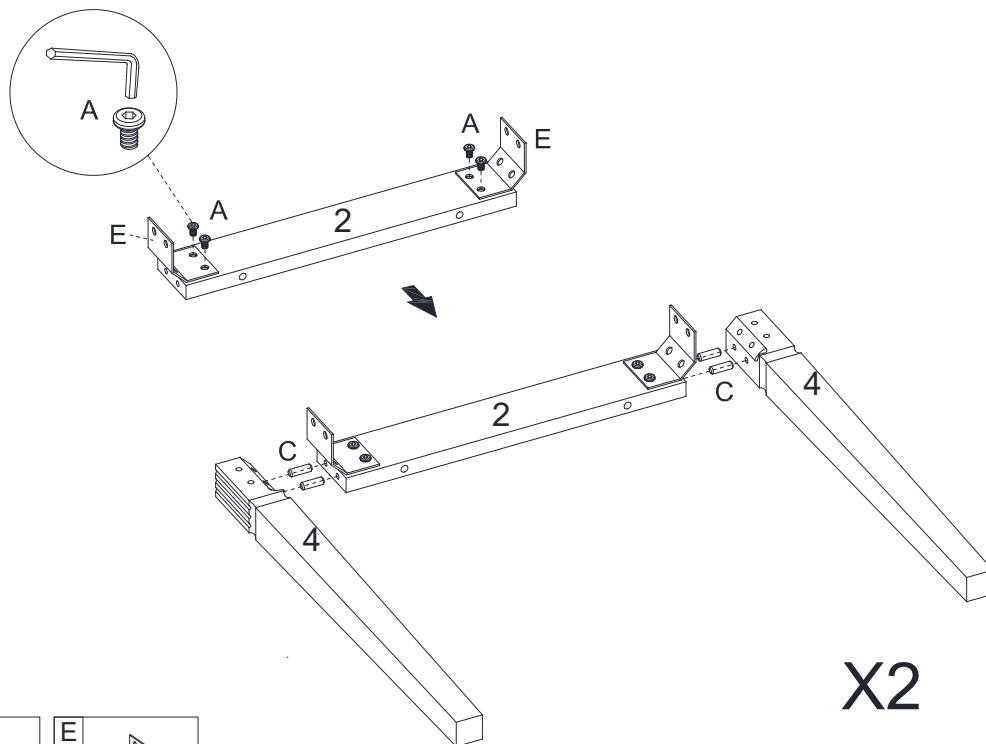
<b>A</b> 	<b>B</b> 	<b>C</b> 	<b>D</b> 	<b>E</b> 	<b>F</b> 
M6*15mm Bolt 16pcs+2pcs extra	Ø7*50mm Screw 10pcs+1pc extra	Ø8*30mm Dowel 28pcs+4pcs extra	Ø10*30mm Dowel 4pcs	Connector 4pcs	Felt Mat 4pcs
<b>H</b> 	<b>G</b> 				
M6*20mm Bolt 8pcs+1pc extra	Allen Key 1pc				

1. Attach Connector to Short Support Bar (2) ,then attach Legs (4) to Short Support Bar (2). The screws are tightened to 80% of their maximum torque.



<b>A</b>		<b>C</b>		<b>E</b>	
	M6*15mm Bolt		Ø8*30mm Dowel		Connector
	8pcs		8pcs		4pcs

2. Attach bolts to the Frame. The bolts are tightened to 80% of their maximum torque.

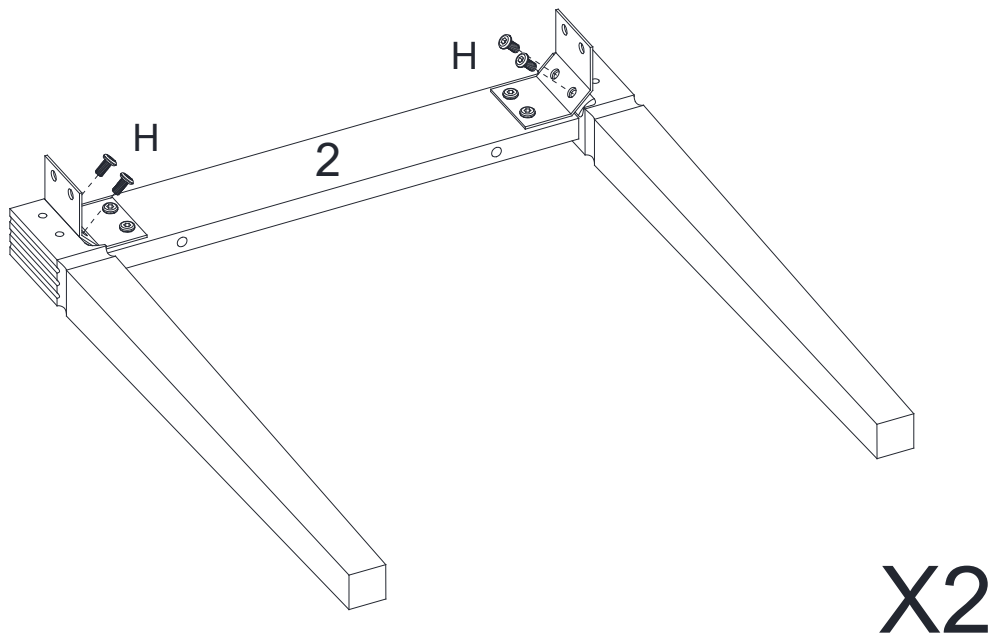

<b>H</b>	
	M6*20mm Bolt
	8pcs

### 3. Attach Long Support Bar (3) to the Frame.

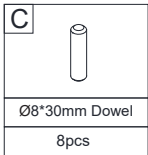
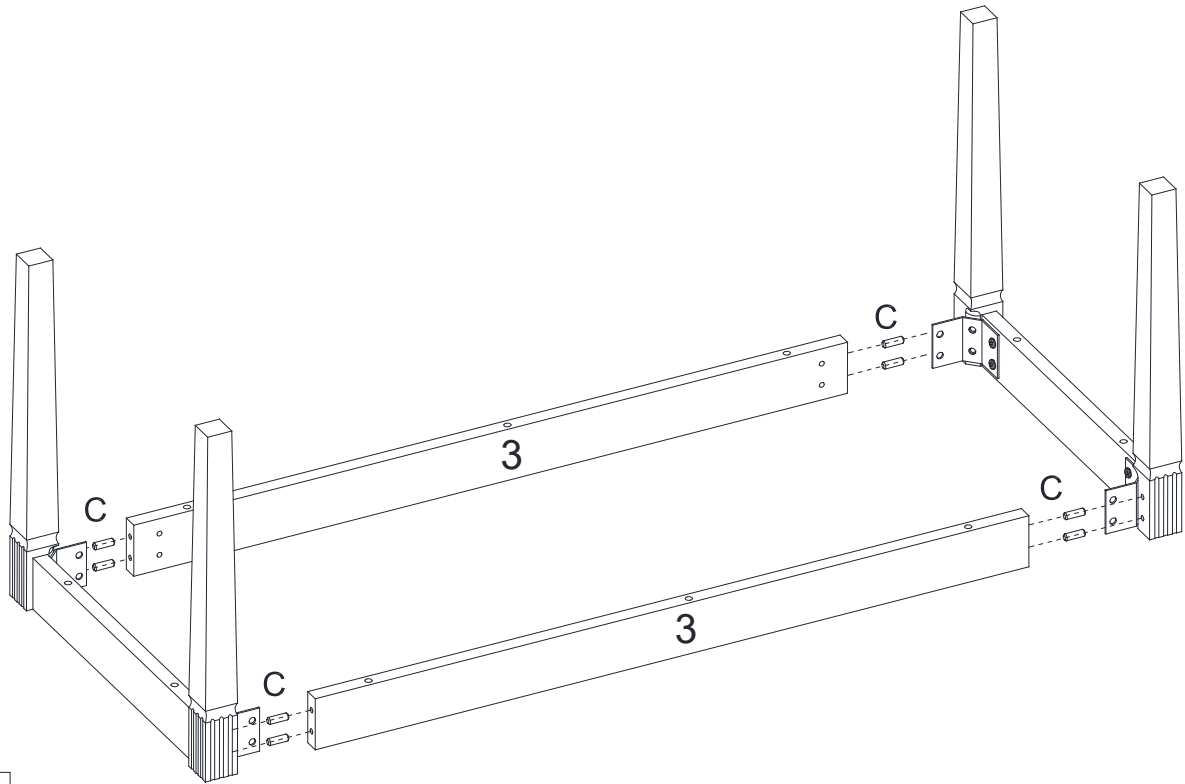

### 4. Attach screws to the Frame. The screws are tightened to 80% of their maximum torque.

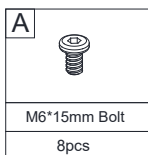
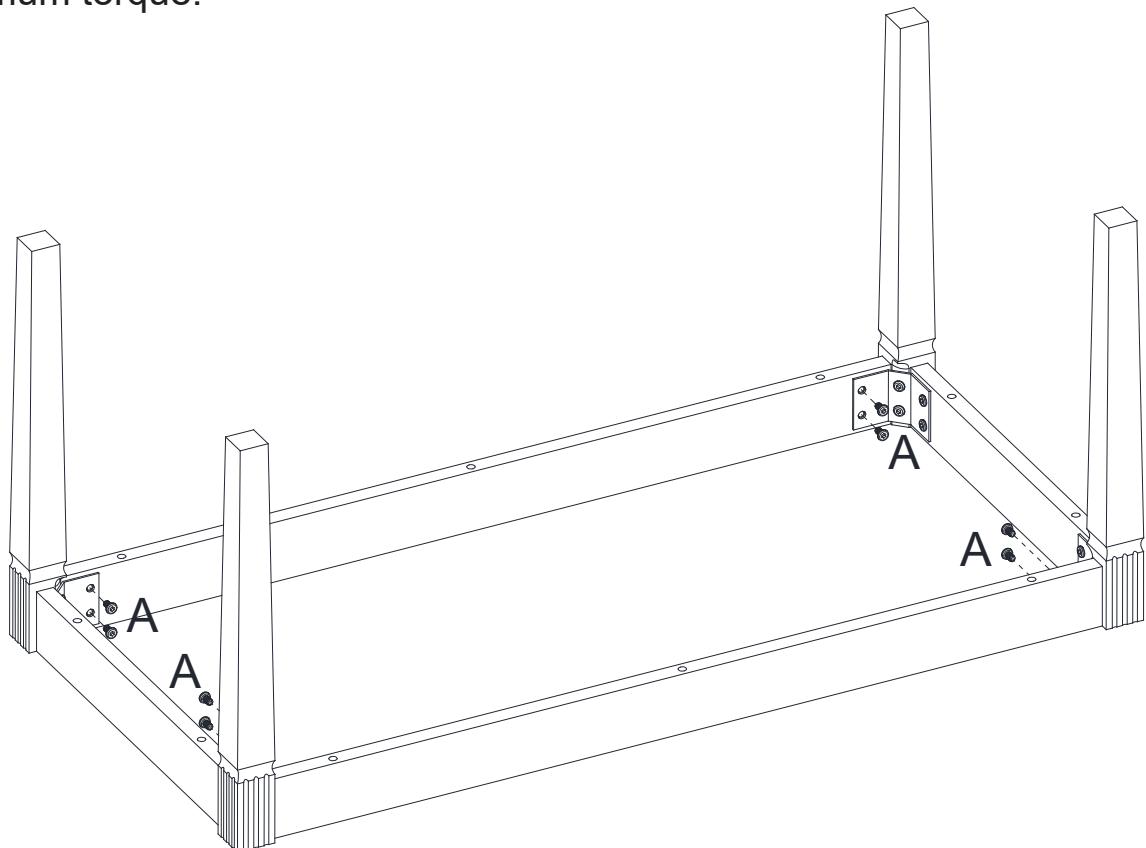

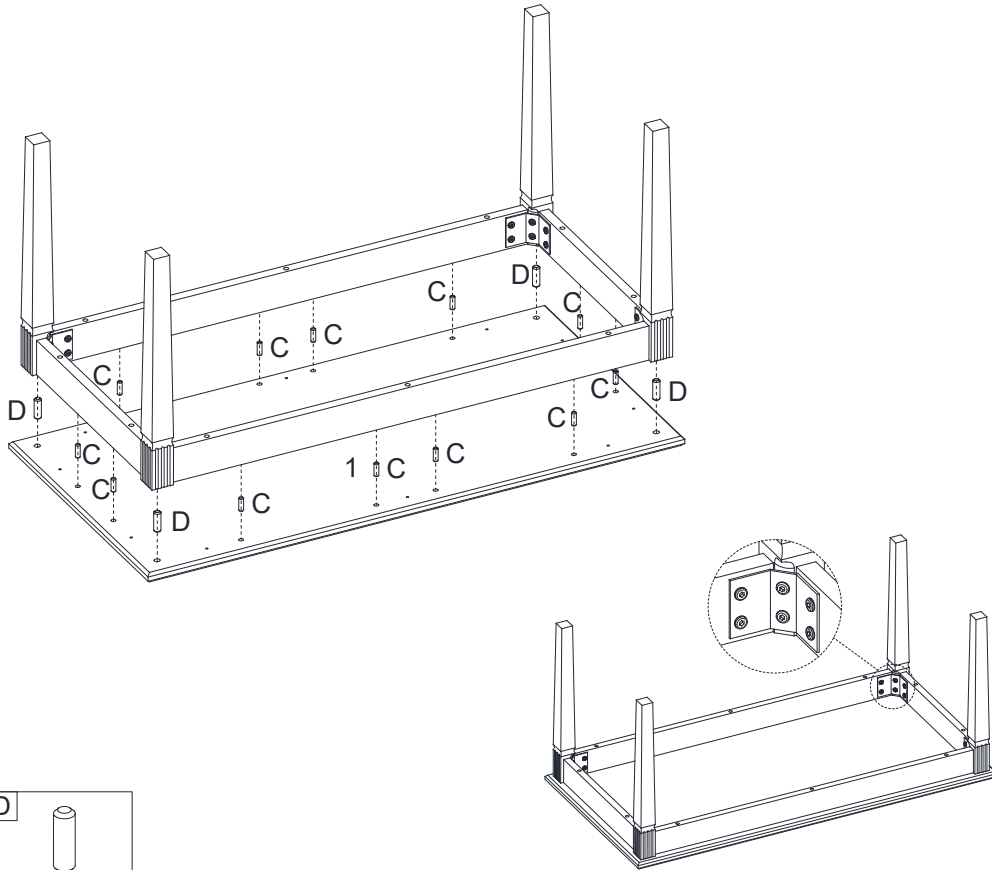

5. Attach Top Panel (1) to the Frame, then tighten 100% of screws.

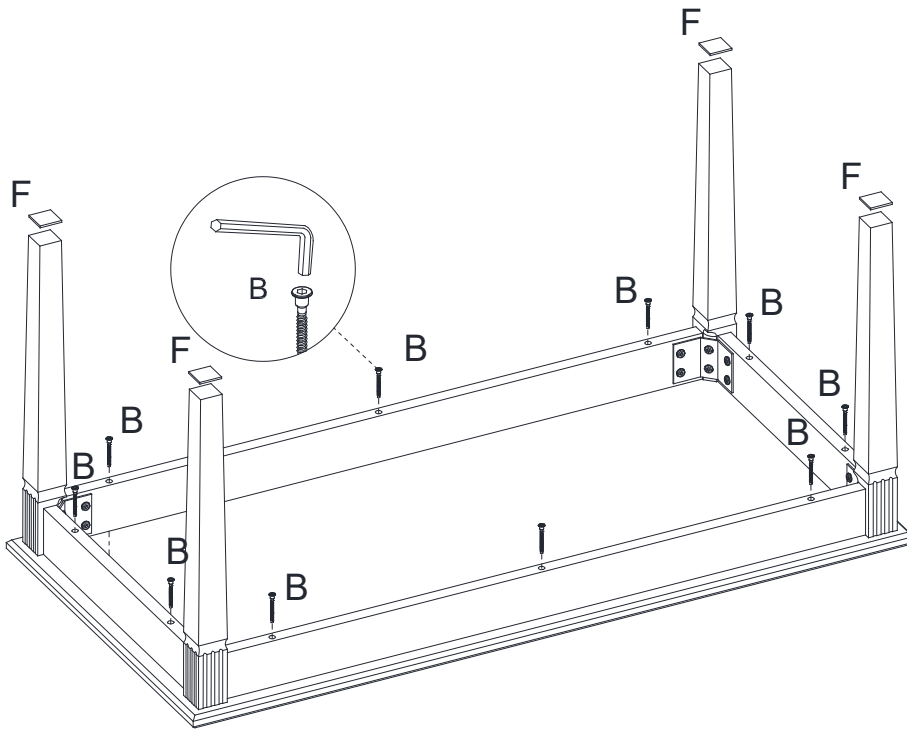

<b>C</b>		<b>D</b>	
	Ø8*30mm Dowel		Ø10*30mm Dowel
	12pcs		4pcs

6. Attach Screws and Felt Pad to the Frame.



<b>B</b>		<b>F</b>	
	M5*40mm Screw		Felt pad
	10pcs		4pcs