

DUSK.COM

LIVING | BEDROOM | DINING

Range Name : PENELOPE

Box 1 Dimensions : W208xD62xH9cm

Box 2 Dimensions : W208xD61xH10cm

Box 3 Dimensions : W105xD80xH11cm

Product Dimension: W150xD61xH198cm

Penelope Wardrobe

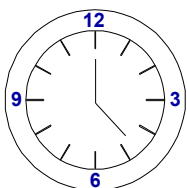
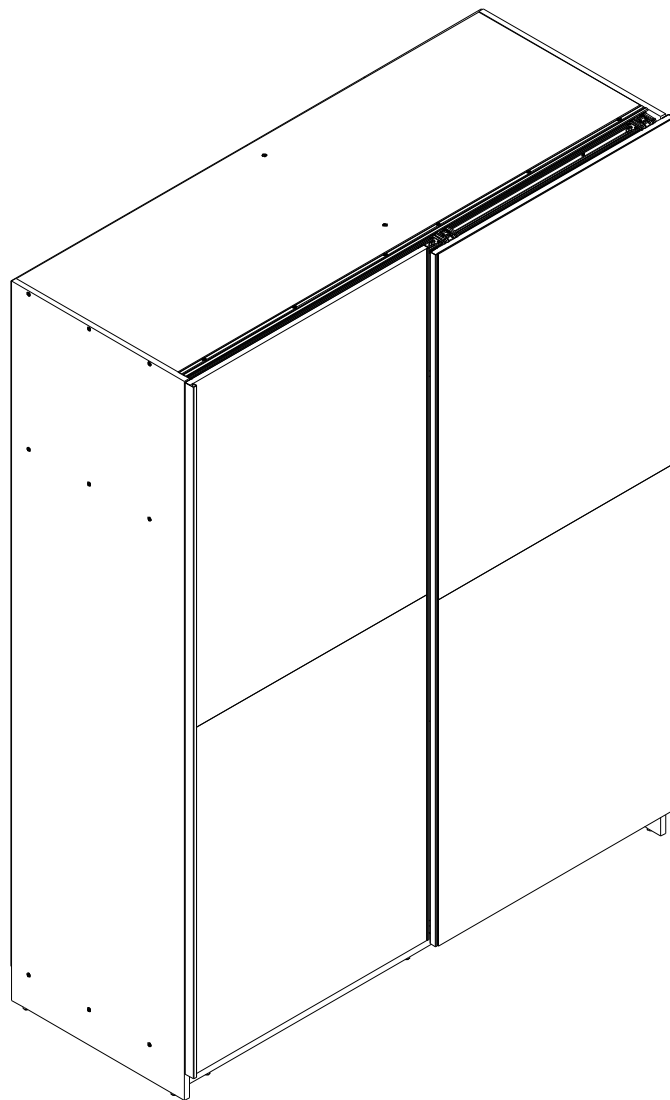

Up to 120 minutes
assembly time

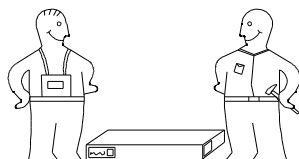

Two person
assembly



Electric screwdriver
prohibited

This product is intended for domestic use only, not for commercial purposes.

IMPORTANT ASSEMBLY TIP

Before you begin, it's best to identify all of the parts and fittings to build your Penelope Wardrobe frame. We advise laying these out on the floor to check you have everything, and to familiarise yourself with all of the parts and fittings before building.

TOP TIP

We recommend that you assemble the Penelope Wardrobe in the room you'd like it to be located.

This will help prevent any risk of damage to the frame whilst moving it.

SAFETY AND CARE

It's important to ensure children and animals are kept away from the assembly area, as there are small components used in this product which could present a choking hazard. All plastic and wrapping materials should also be kept away from children and animals to prevent any risk of suffocation.

HELP AND SUPPORT

Please contact our customer service team on 0113 519 0311 if you have any questions or issues with your purchase.





RECYCLING

Please ensure that packaging is disposed of in a safe and environmentally friendly way, and recycle where possible. Please keep your assembly instructions safe to refer back to in the future.

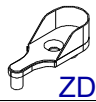

CARE AND MAINTENANCE:

1. Only clean using a damp cloth, do not use bleach or abrasive cleaners as they may damage the finish over time.
2. Do not use a very wet cloth or allow any liquid to contact with the veneer for a long period of time. Wipe any spillage immediately. Absorption can cause wood to warp or finishes to de-laminate.
3. Do not scrub or rub the surface when cleaning.
4. Do not drag the Penelope Wardrobe when moving, lift it off the floor instead.
5. Use a placemat or a coaster when putting hot items (e.g. hot drinks and dishes) on the wood surface.
6. It is not recommended to place the item next to sources of heat such as radiators, fires or directly exposed to sunlight. This may cause the wood to crack, split or fade due to the heat and humidity.
7. Wood will mellow and change colour over time, we recommend that ornaments and items placed on the surface to be moved regularly to prevent uneven mellowing.
8. Regularly check all fixings to ensure none have come loose. Re-tighten if necessary.
9. Avoid sharp items such as a screwdriver or any pointy tools.
10. Dispose of all packaging carefully and responsibly - recycle where possible.

I-VII

 3x13 H x4	 ZD x4	 V1 x10	 D x24	 4x13 H20 x8
---	---	--	---	---

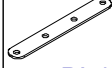

VIII-IX

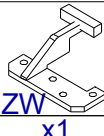
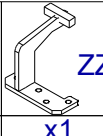
 3,5x16 H6 x32	 4x13 H20 x48	 BL4 x4
---	--	--

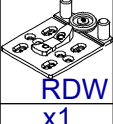
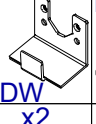
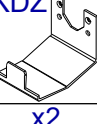
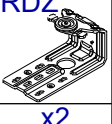
 ZW x1	 ZZ x1
---	---

 RDWS x1	 RDW x1	 KDW x2	 KDZ x2	 RDZ x2
--	--	--	--	--

X-XVIII

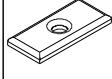
 U x1	 7x50 O x36	 3x20 H2 x50	 PD1 x10
--	--	---	---

Box 2

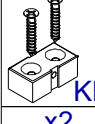

Box 1

 KP x2

XIX-XXIII

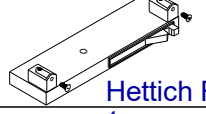
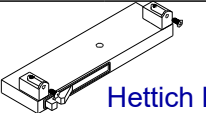
 4x13 H20 x6

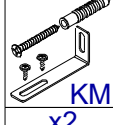
 Hettich R x1
 Hettich L x1

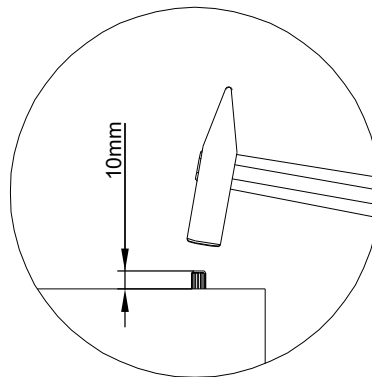

 KM x2	 X3 x36
--	--

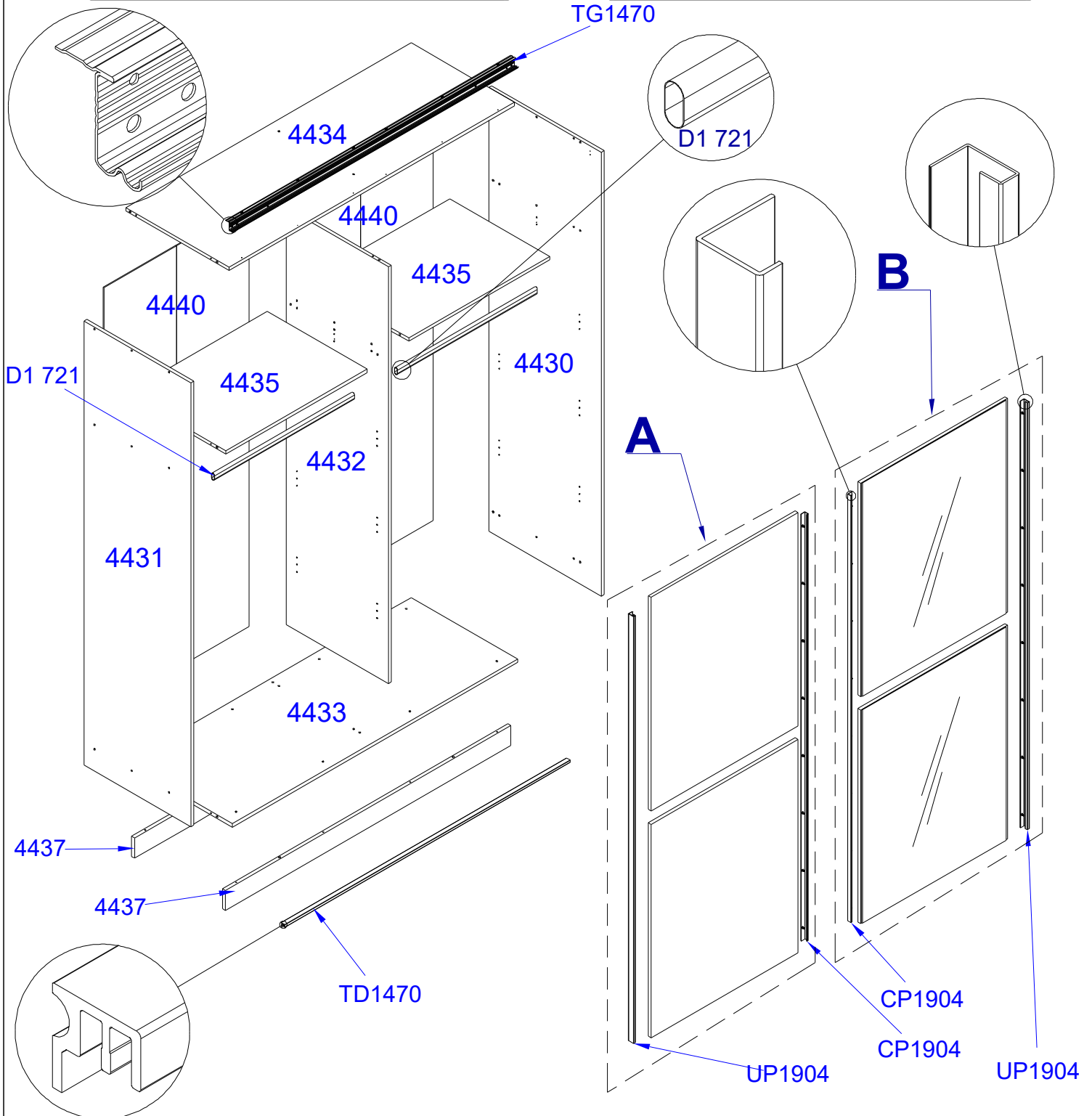
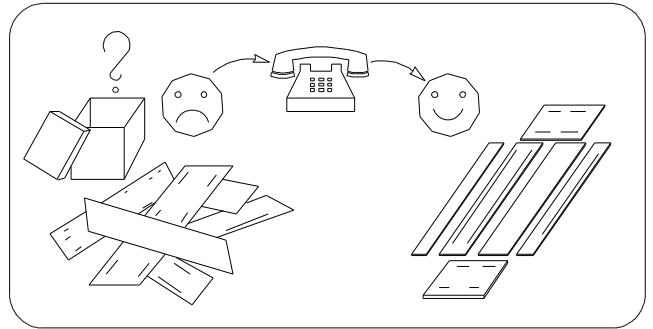
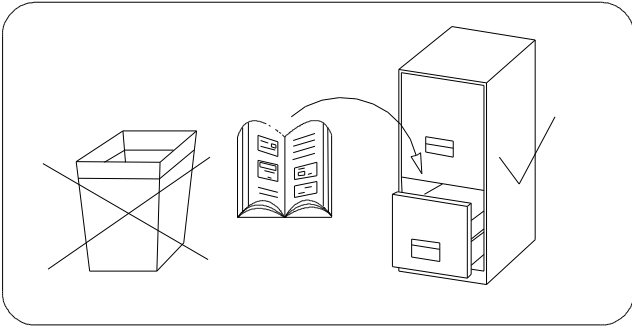

PENELOPE WARDROBE



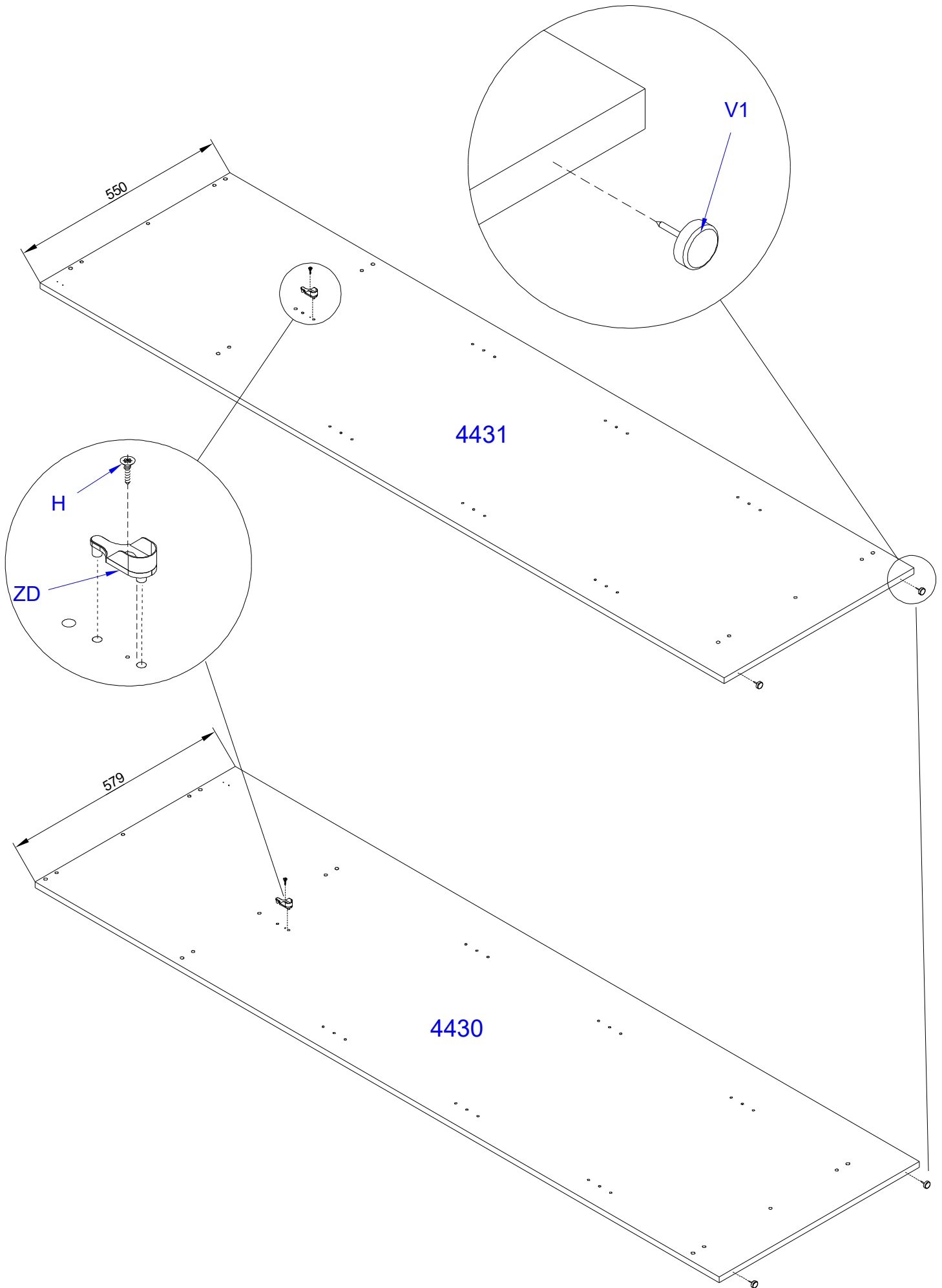

I

3x13 		
H x2	ZD x2	V1 x4



II

3x13 		
H x2	ZD x2	D x4

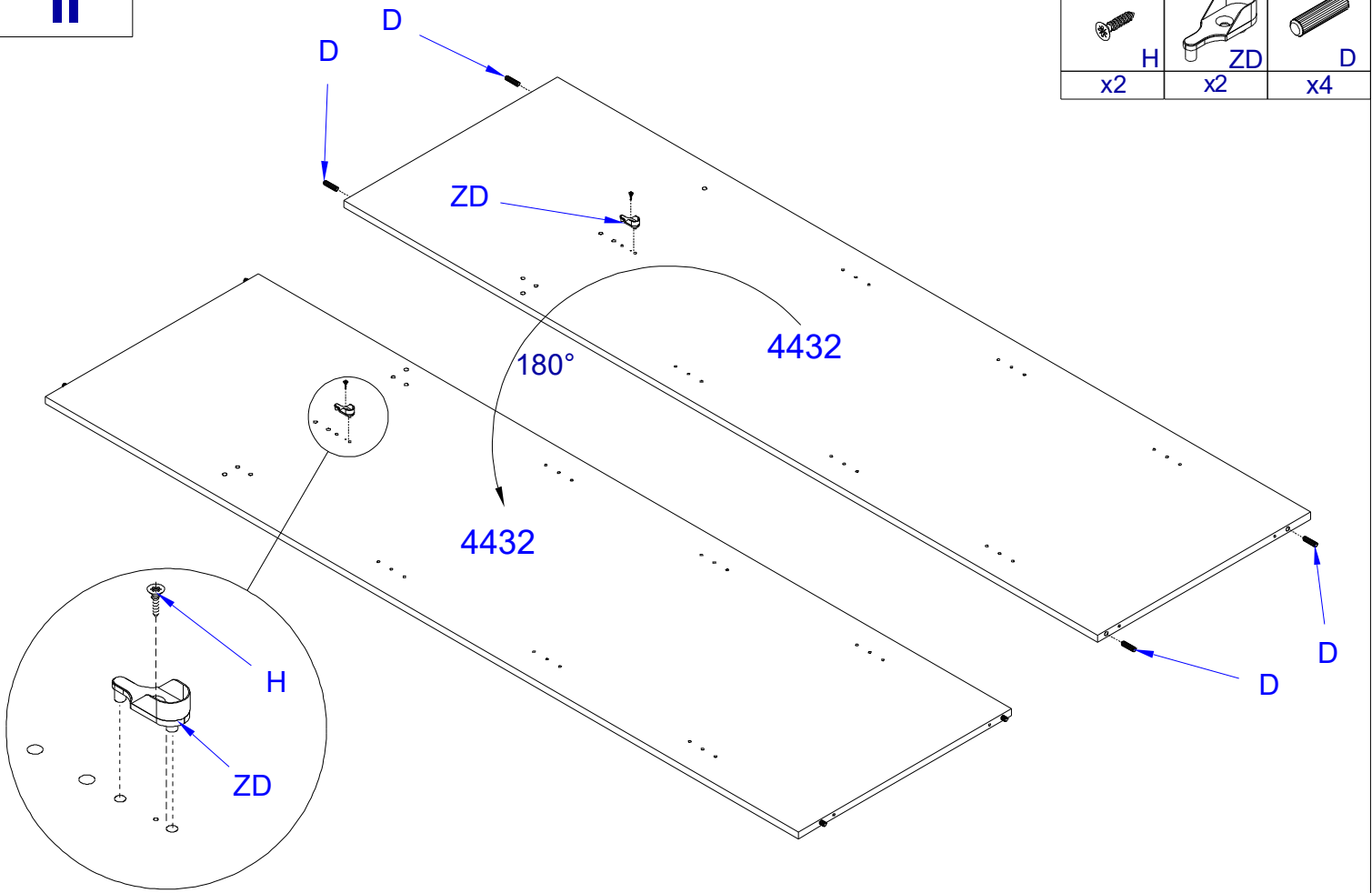

III

D x4

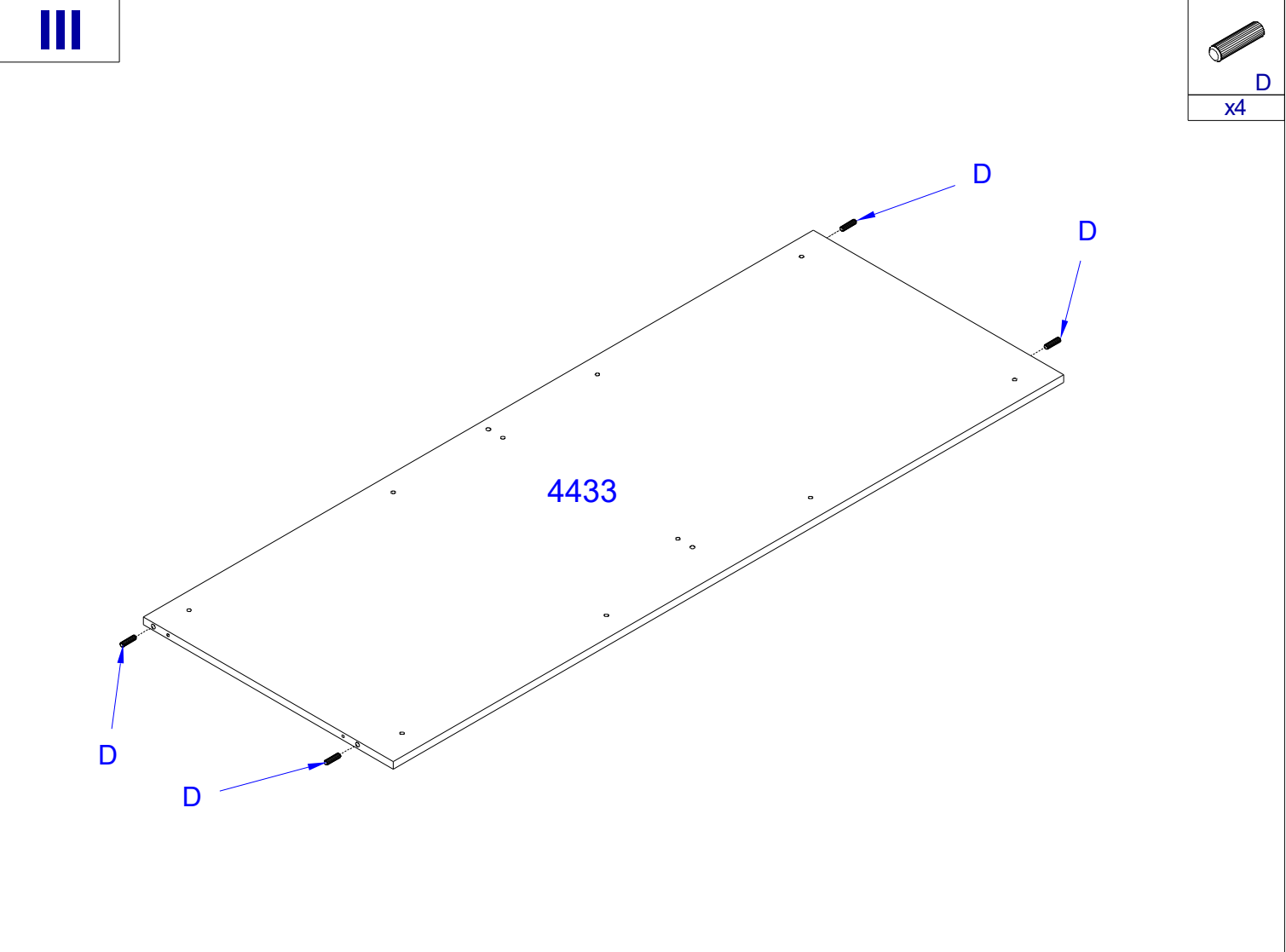

IV



D

x4

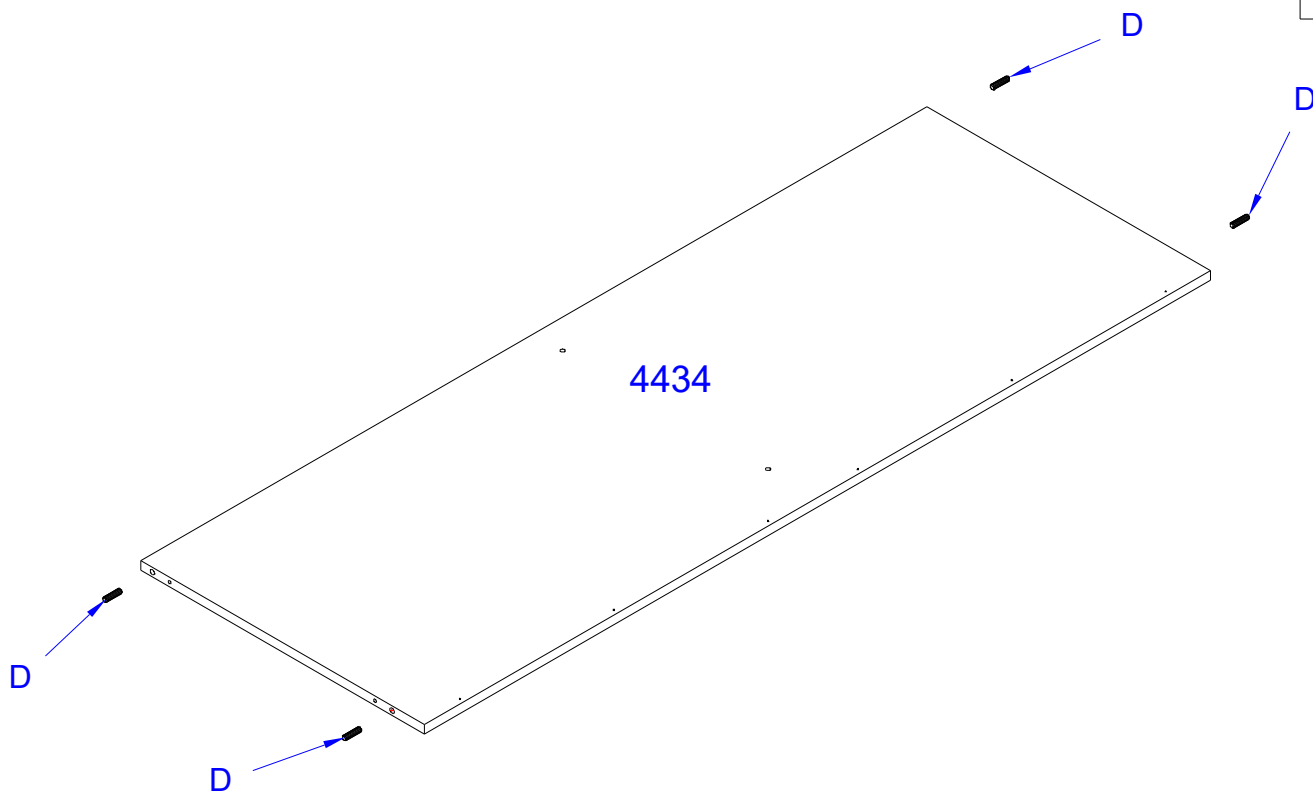

V



D

x8

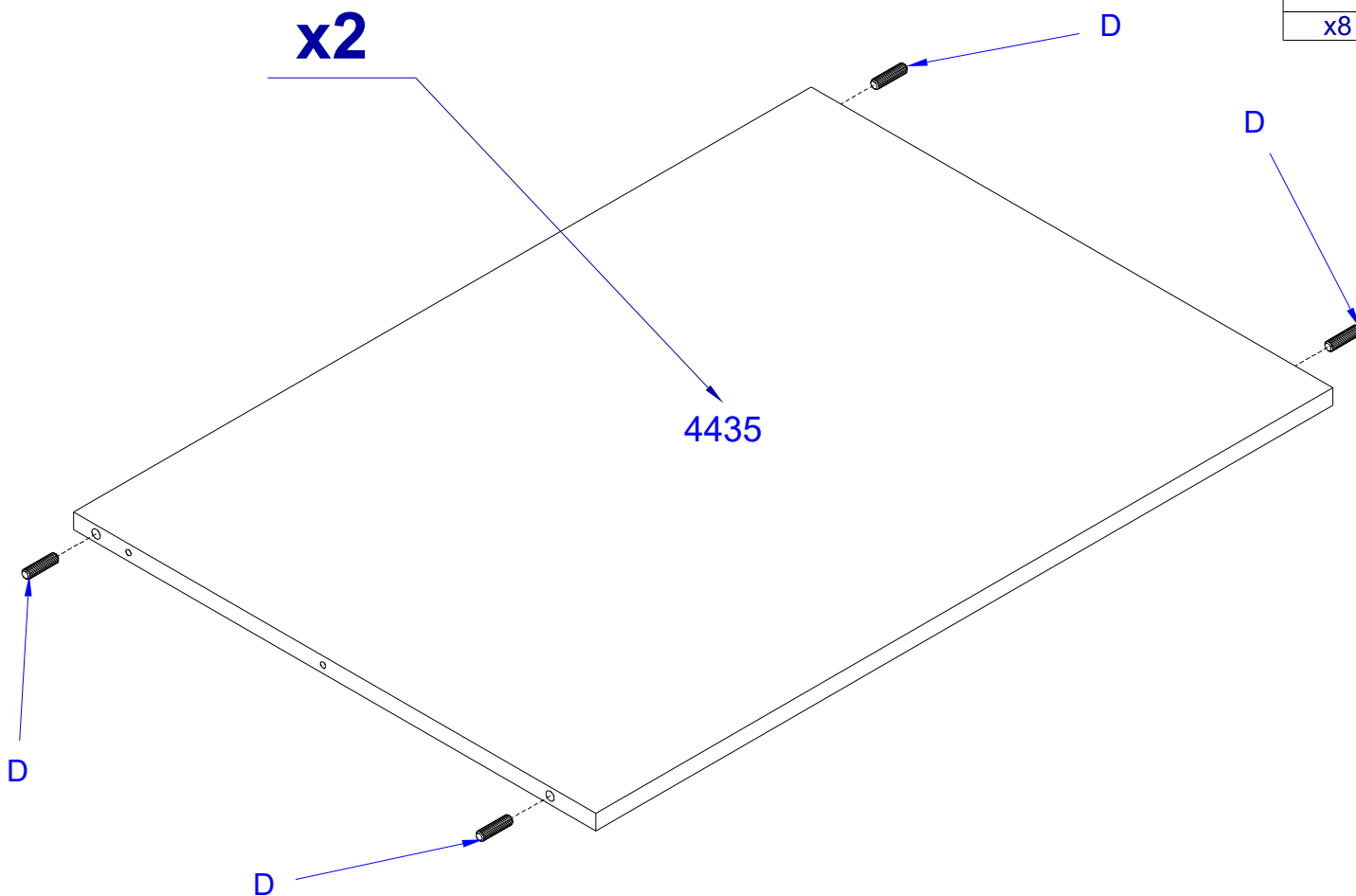

VI

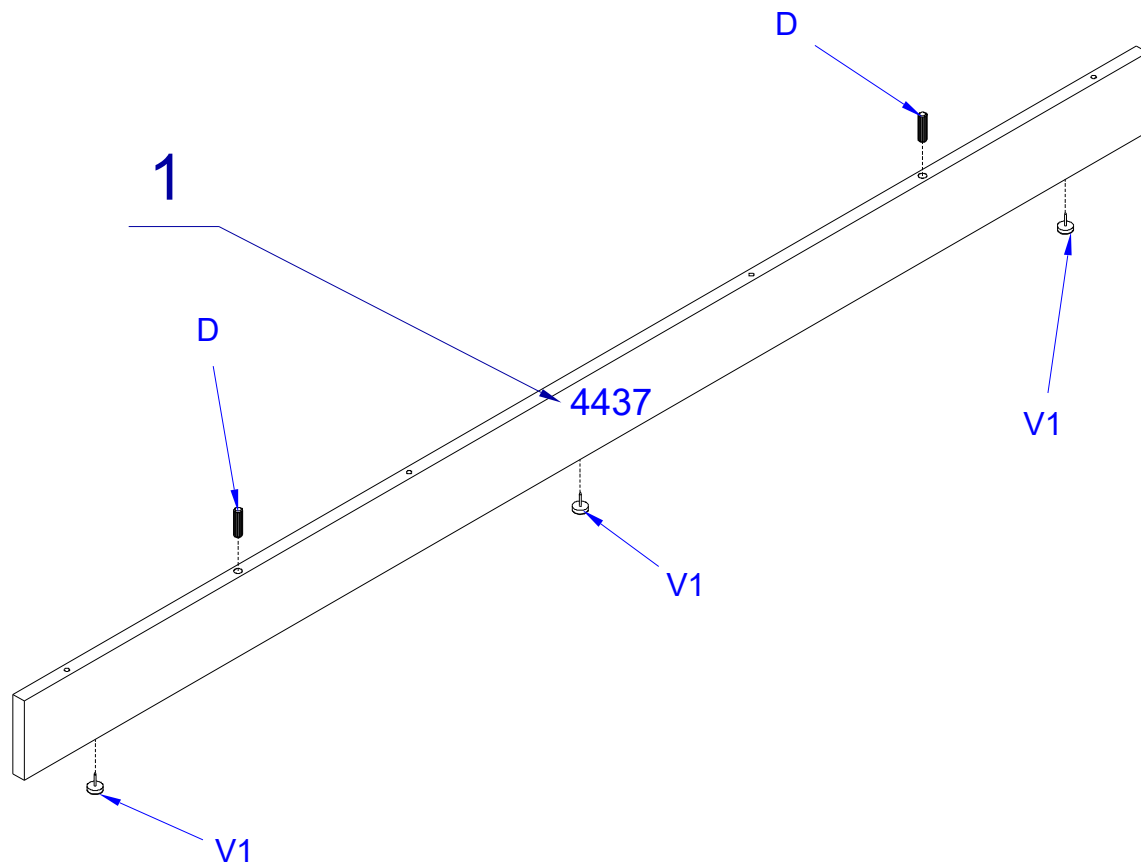

D

x2



V1

x3

VII

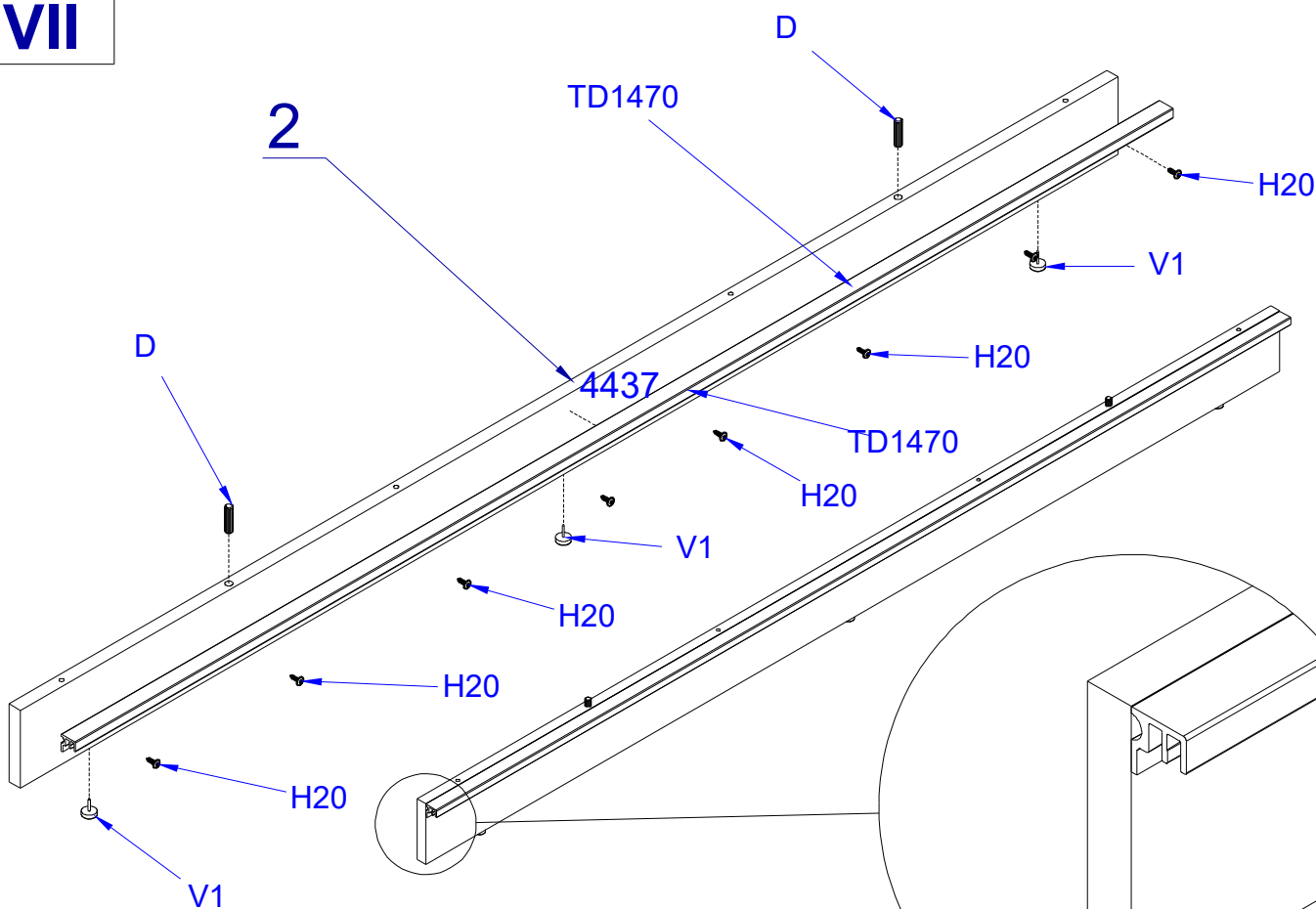

D

x2



V1

x3







4x13

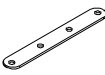

H20

x8

IX

3,5x16  H6 x16	4x13  H20 x24	 BL4 x2	 ZZ x1	 KDZ x2	 RDZ x2
---	--	---	--	---	---

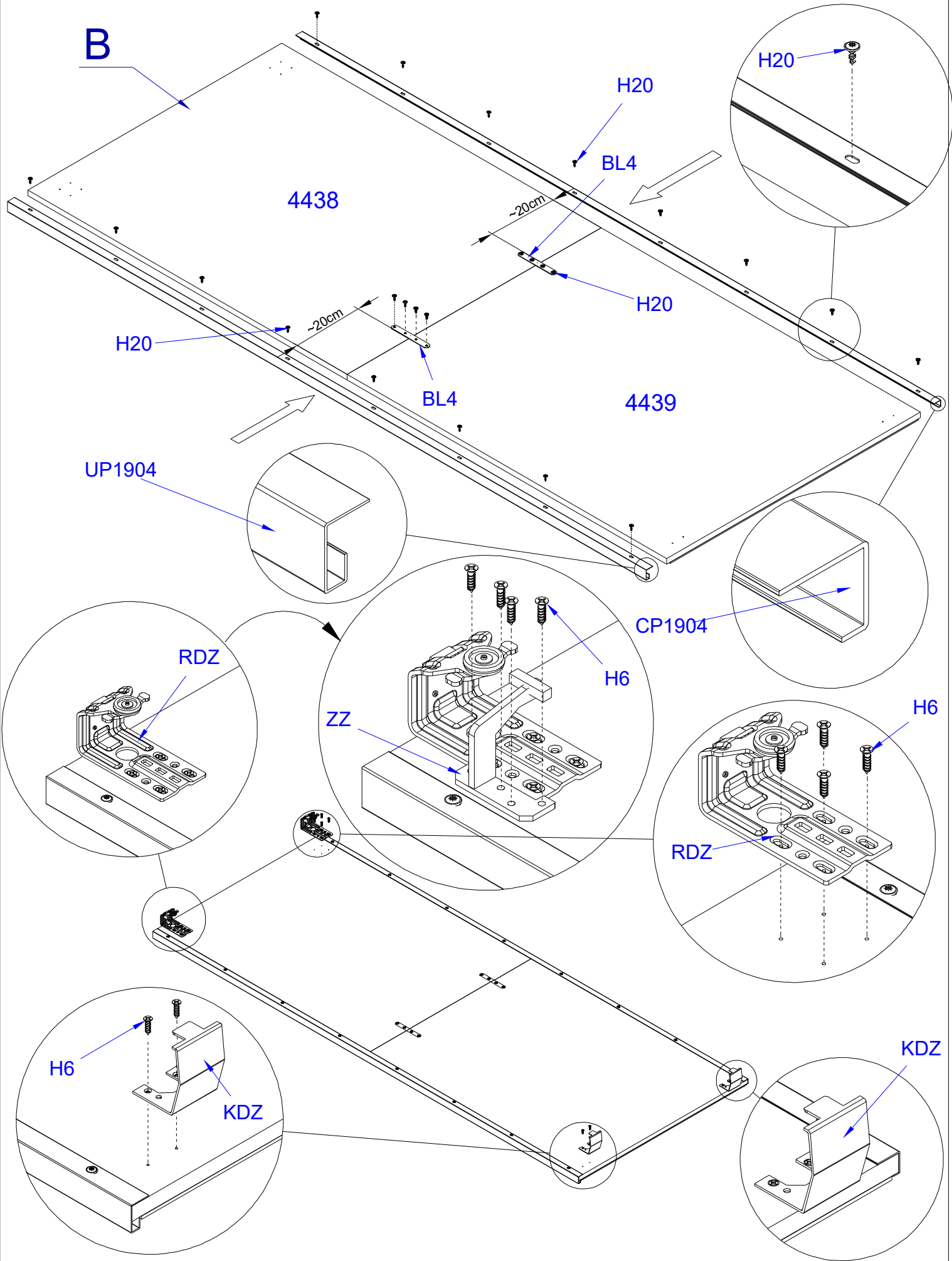

X

7x50



x8

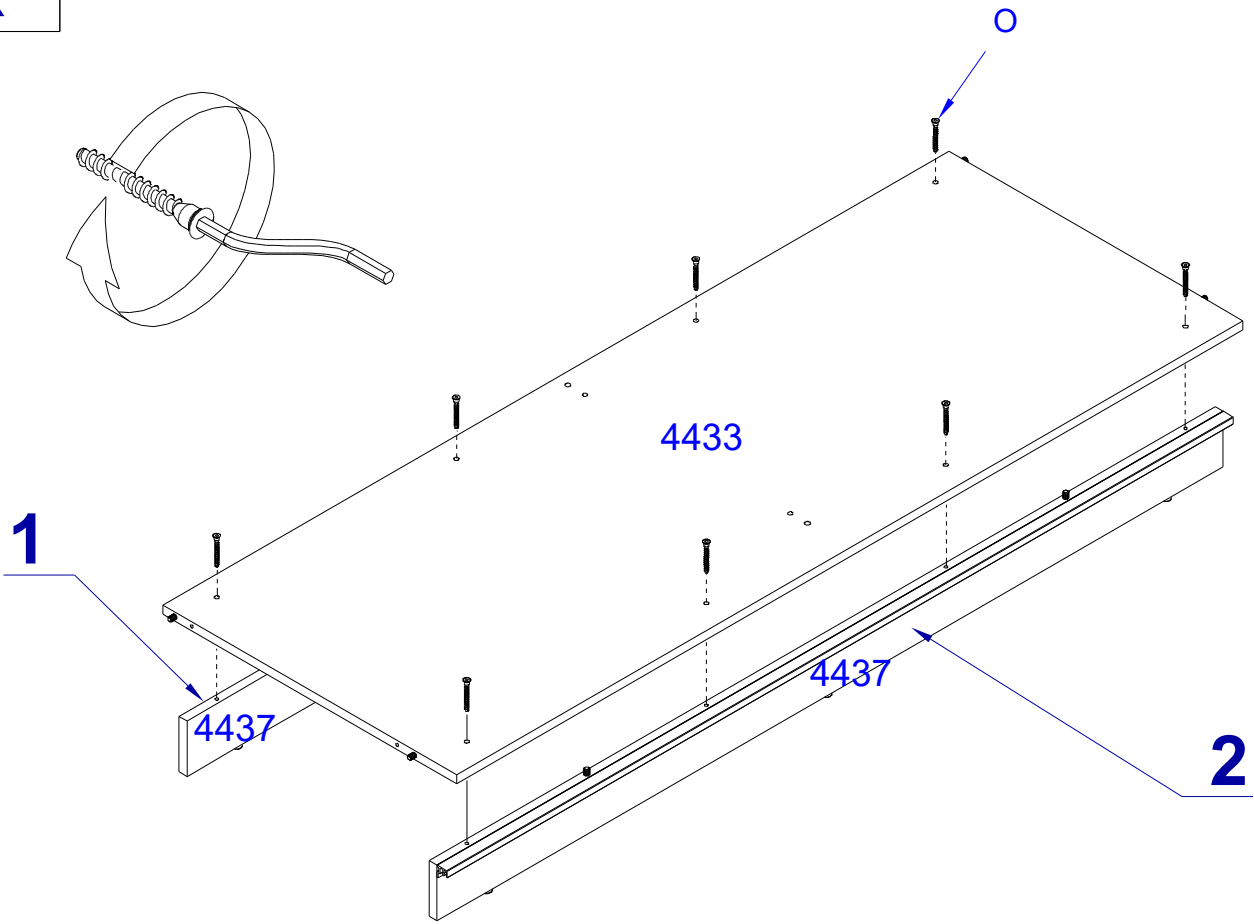

XI

7x50



x2

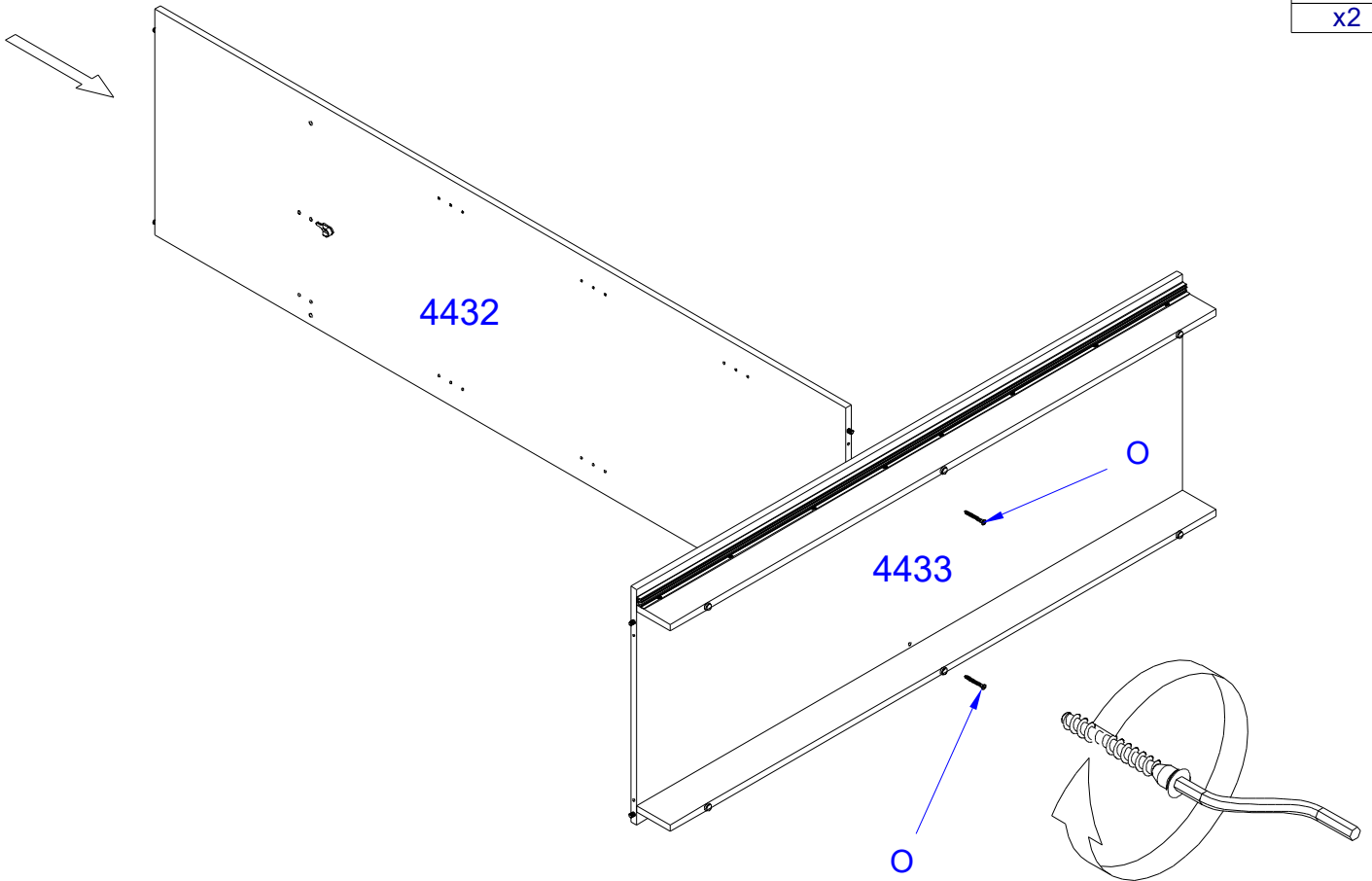

XII

7x50



x2

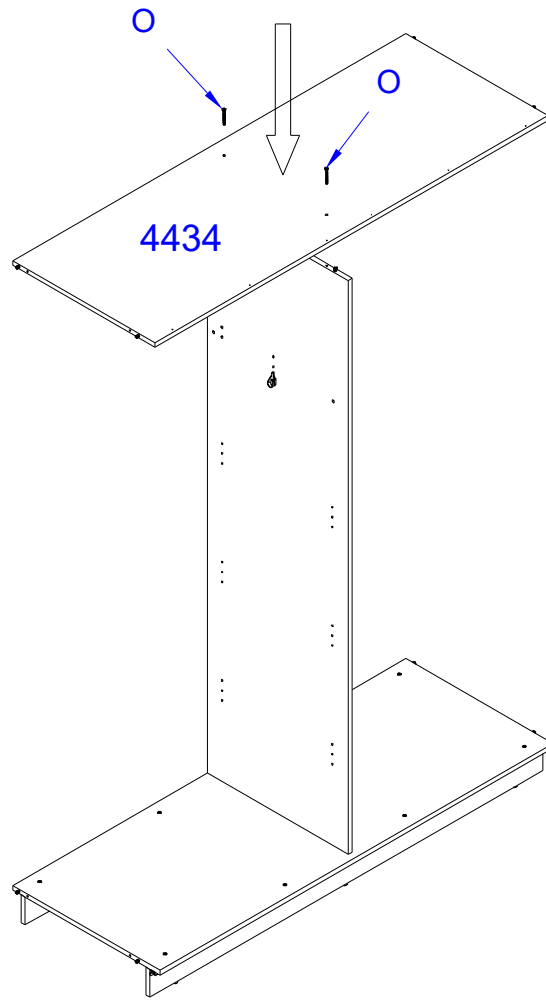
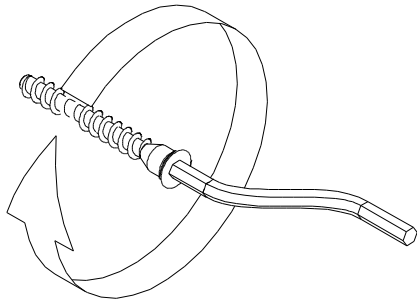

XIII

7x50



3

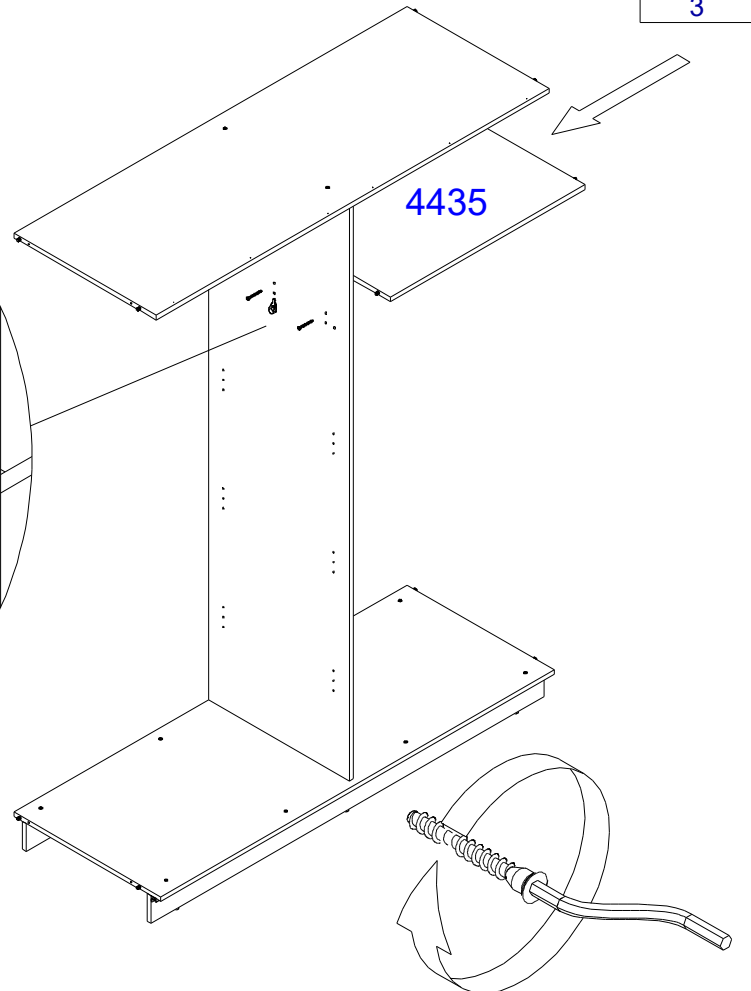
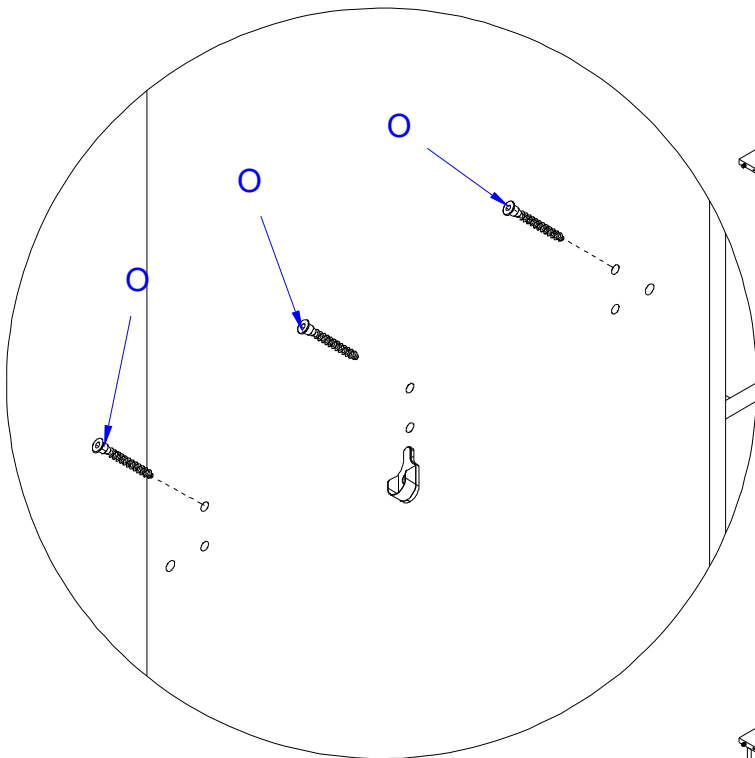

XIV

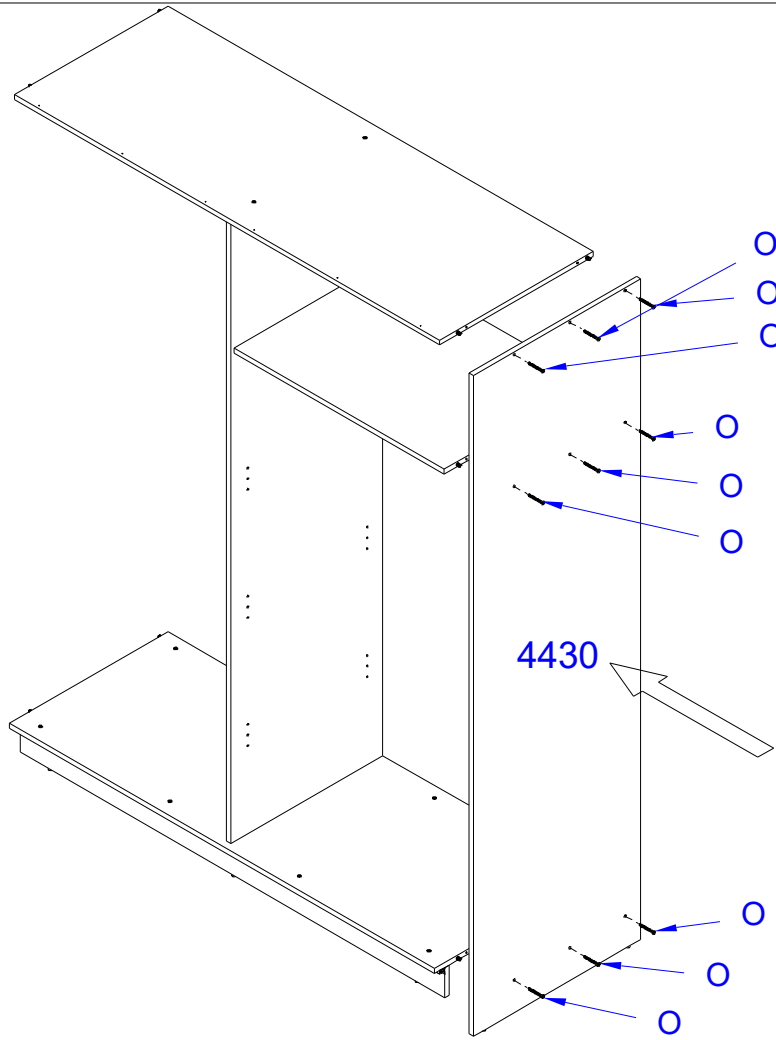

7x50



O

x9

XV

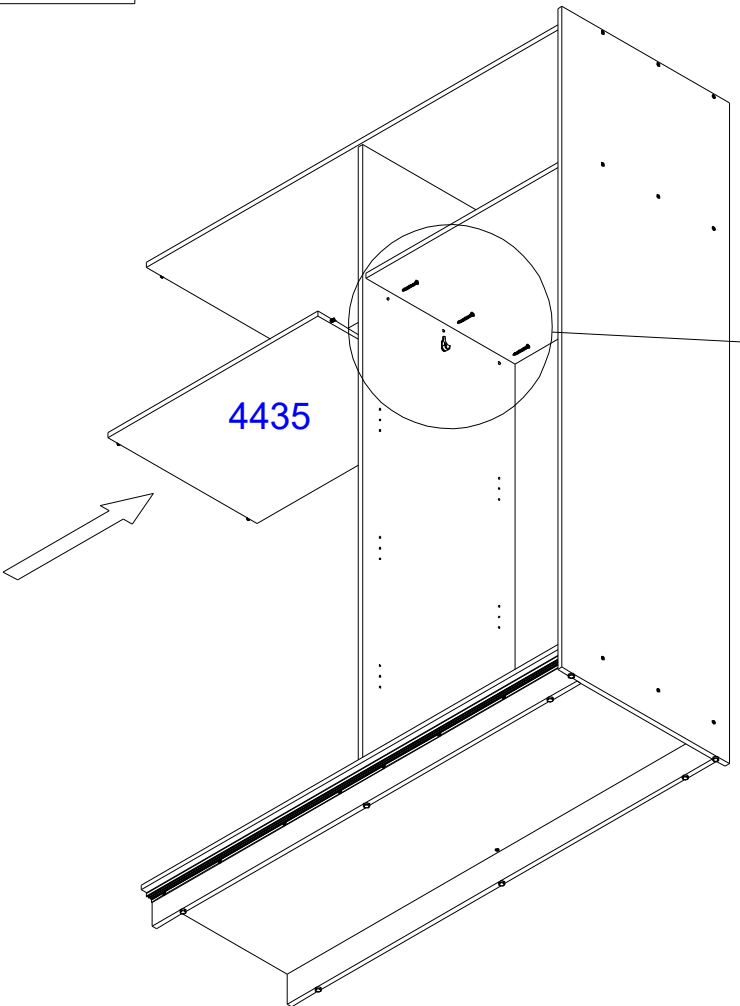

7x50



O

x3

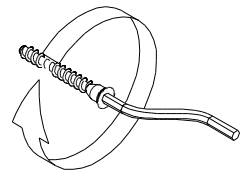
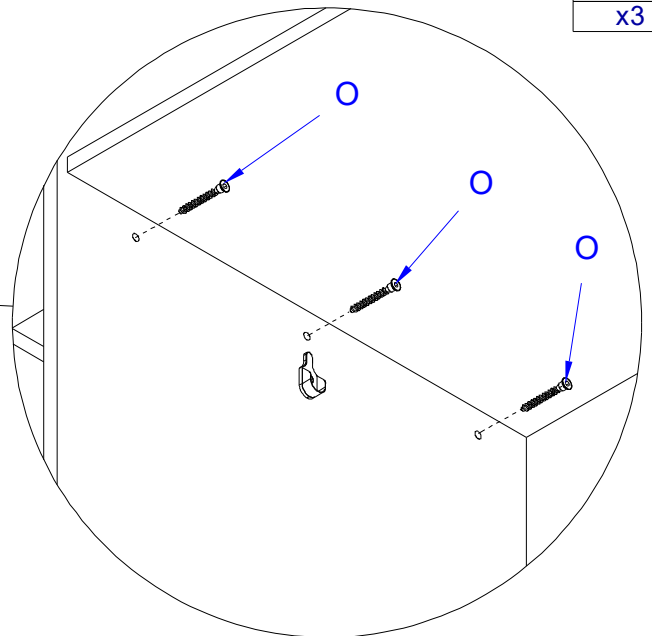

XVI

7x50



x9

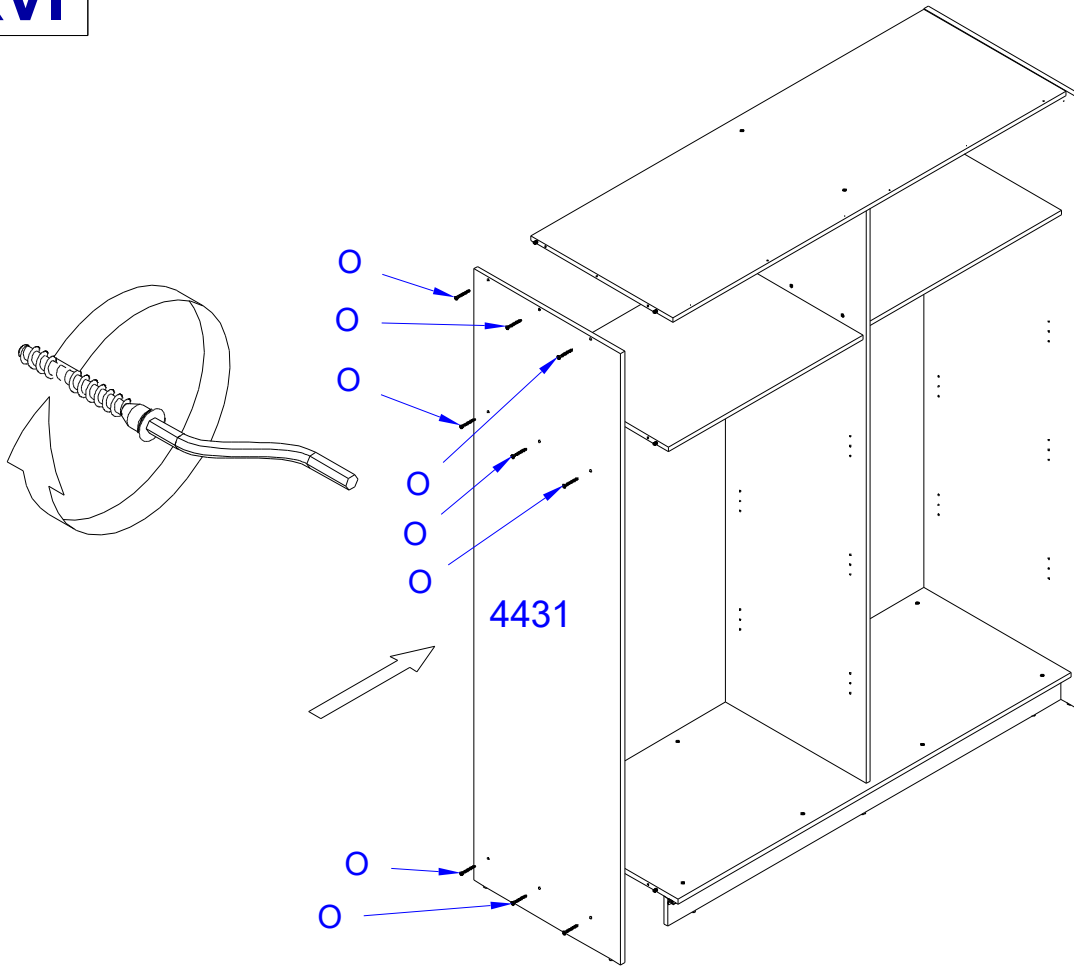

XVII

3x20



H2
x50

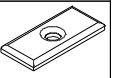

PD1
x10

X=Y

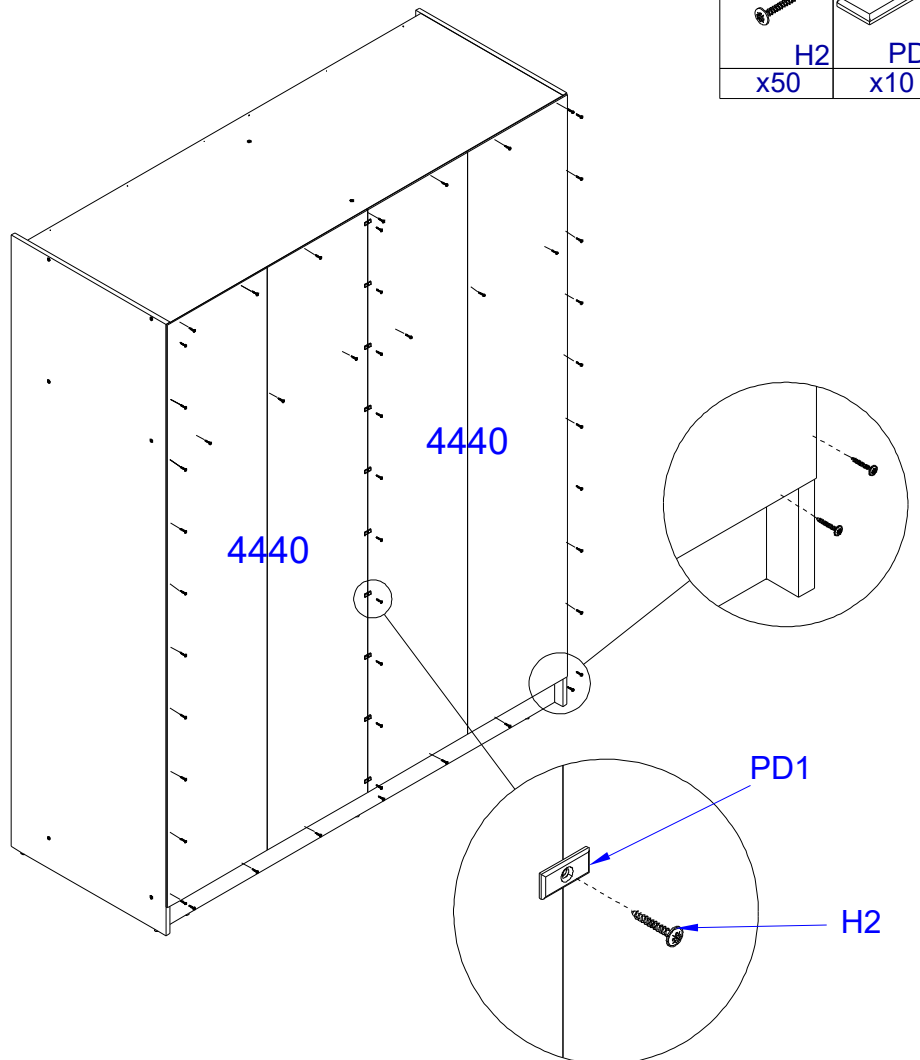
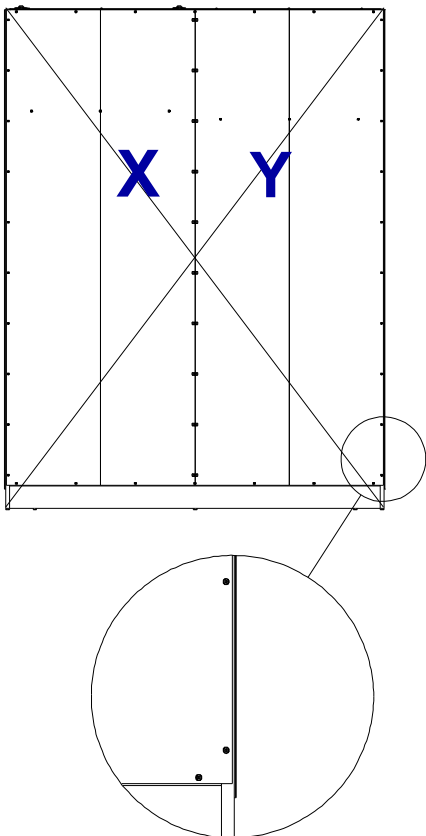

XVIII

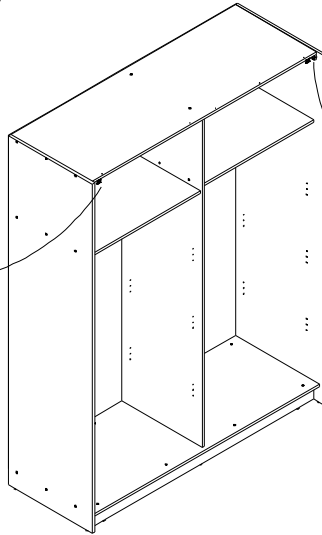
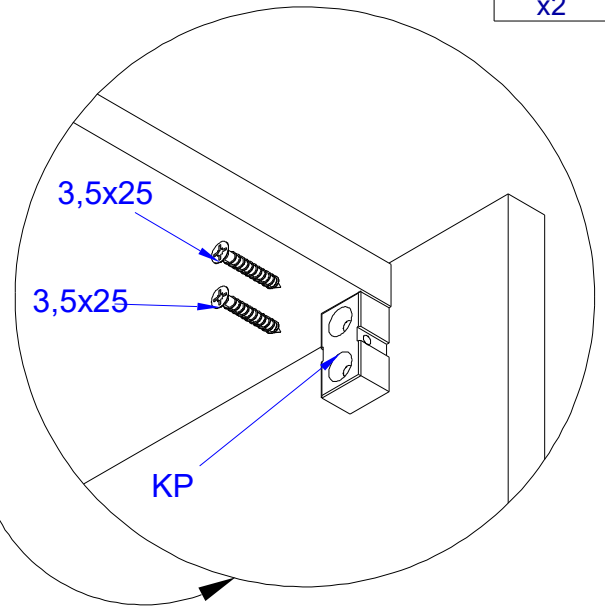
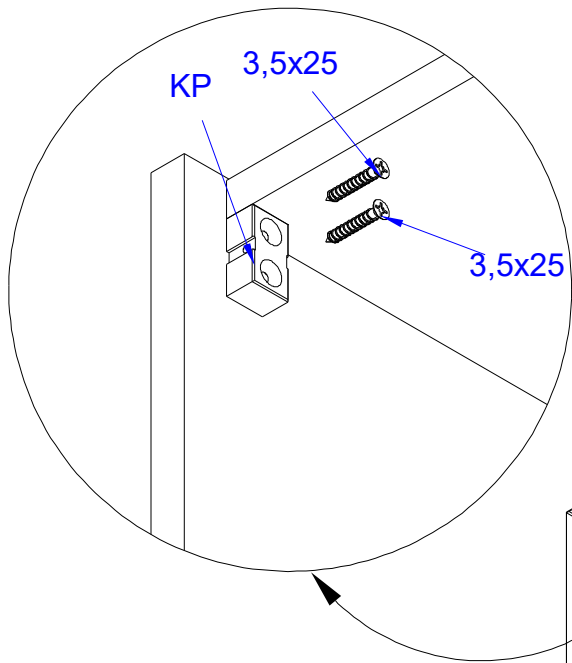
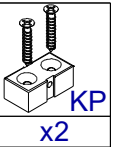

XIX

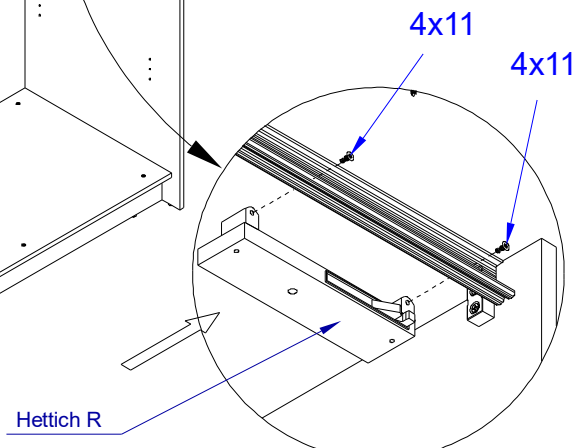
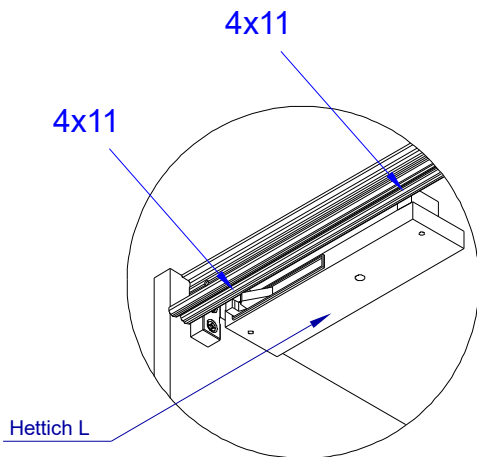
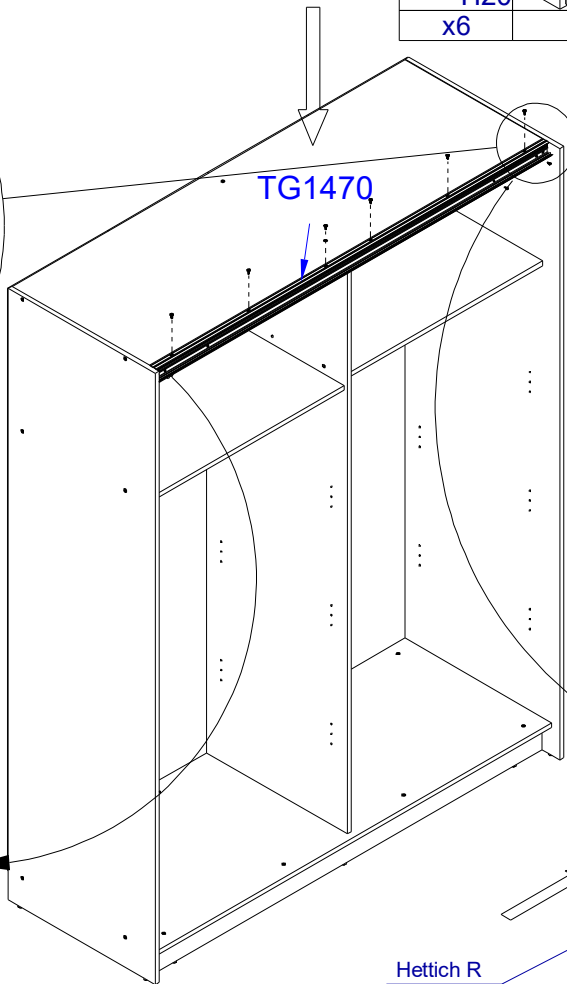
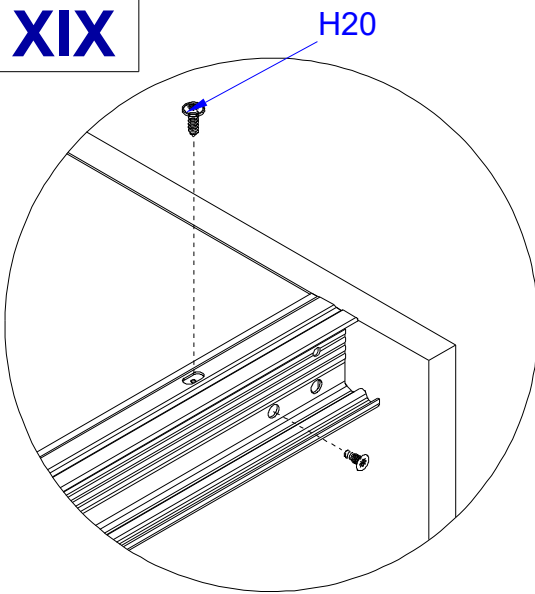
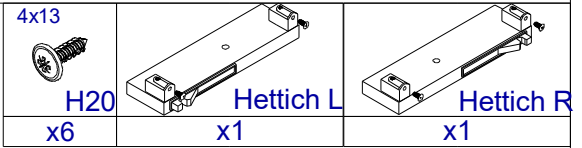

XX

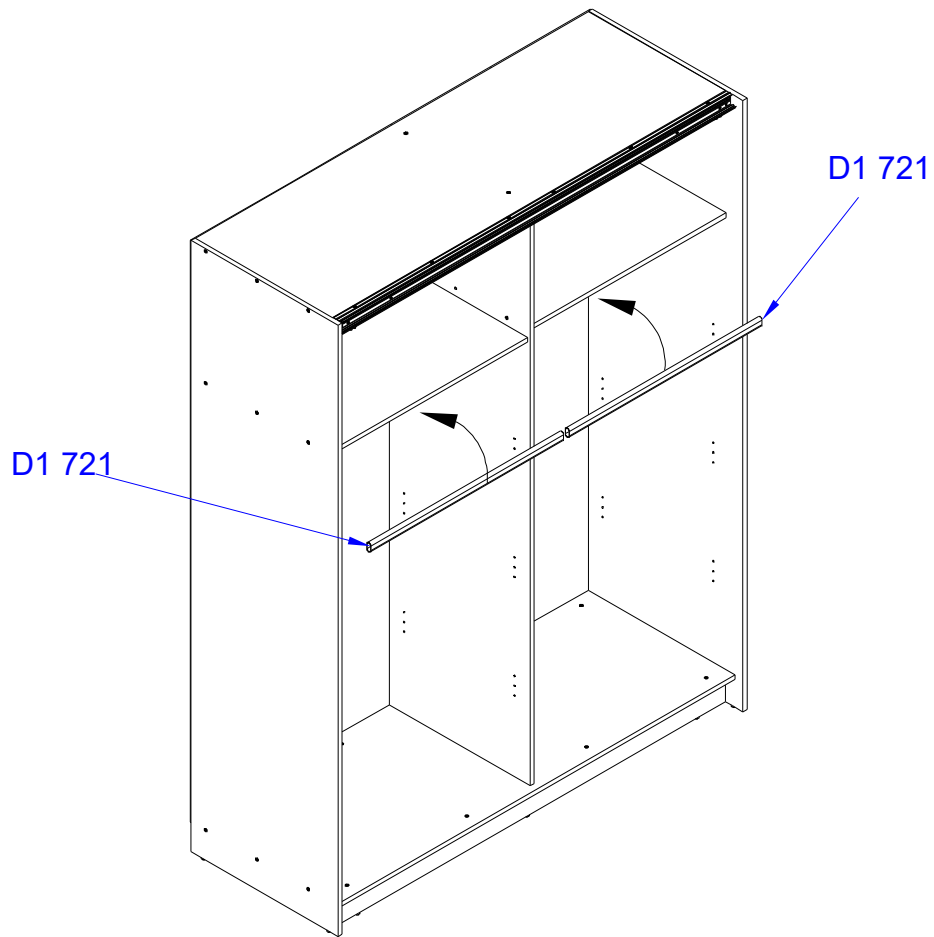

XXI

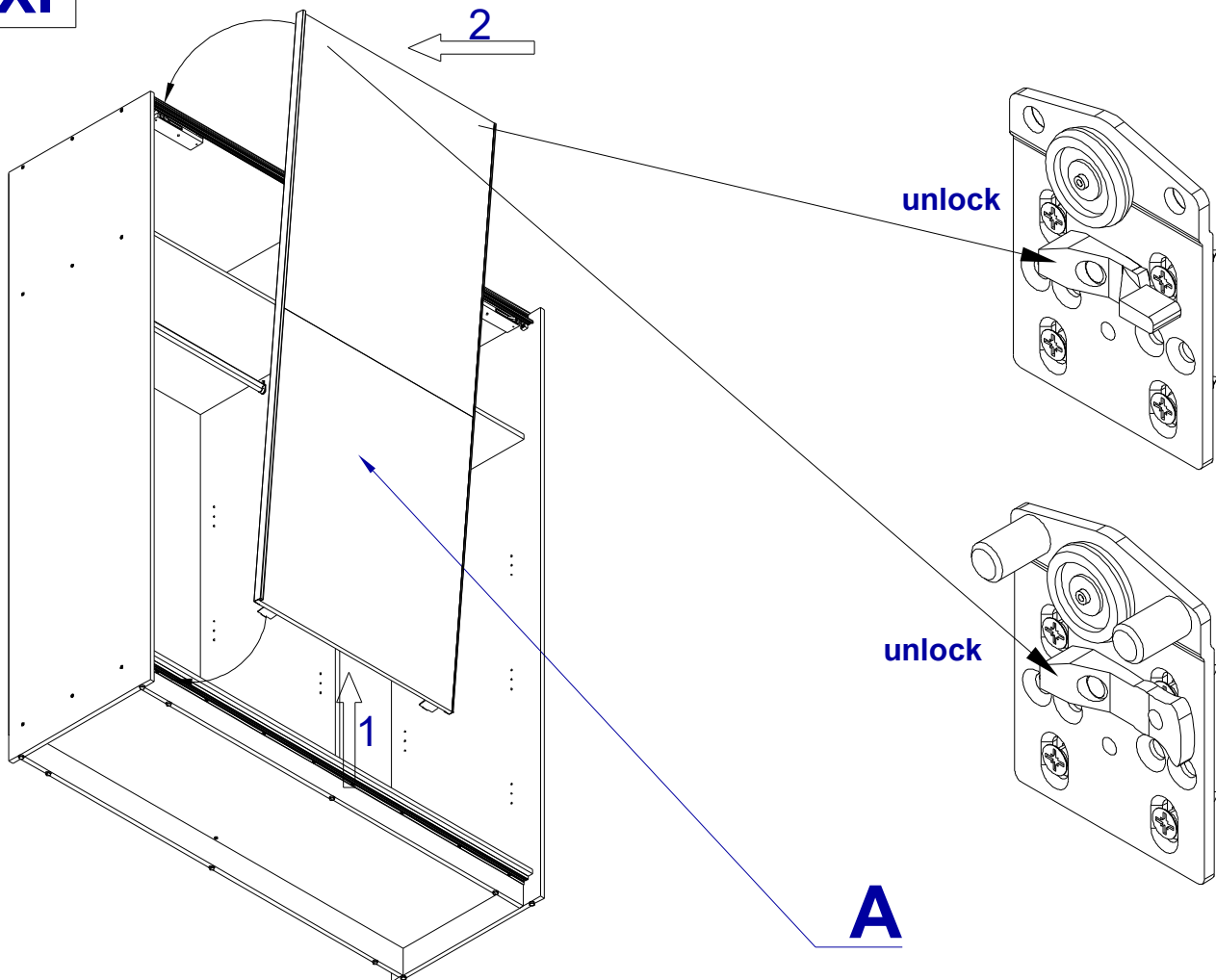

XXII

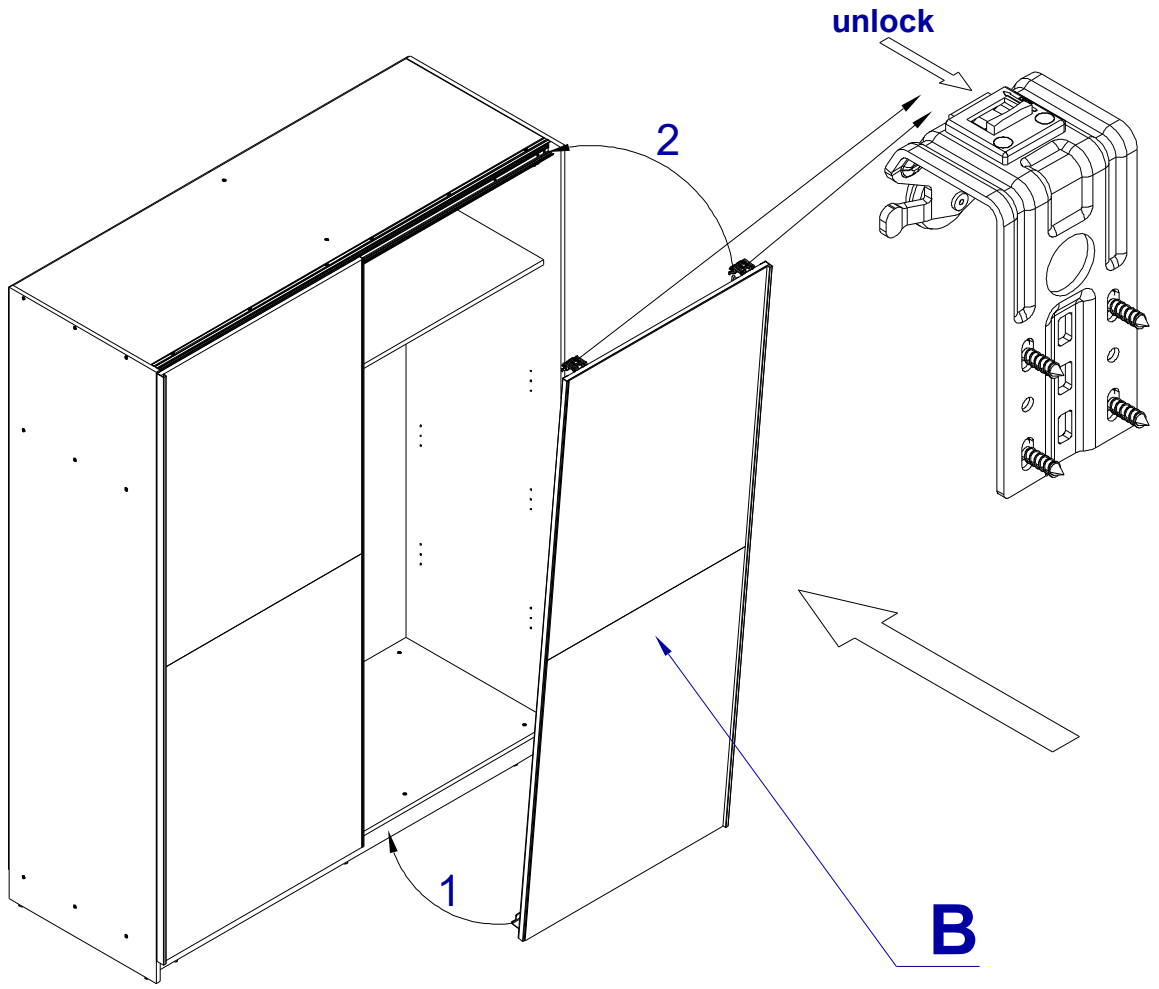

XXIII

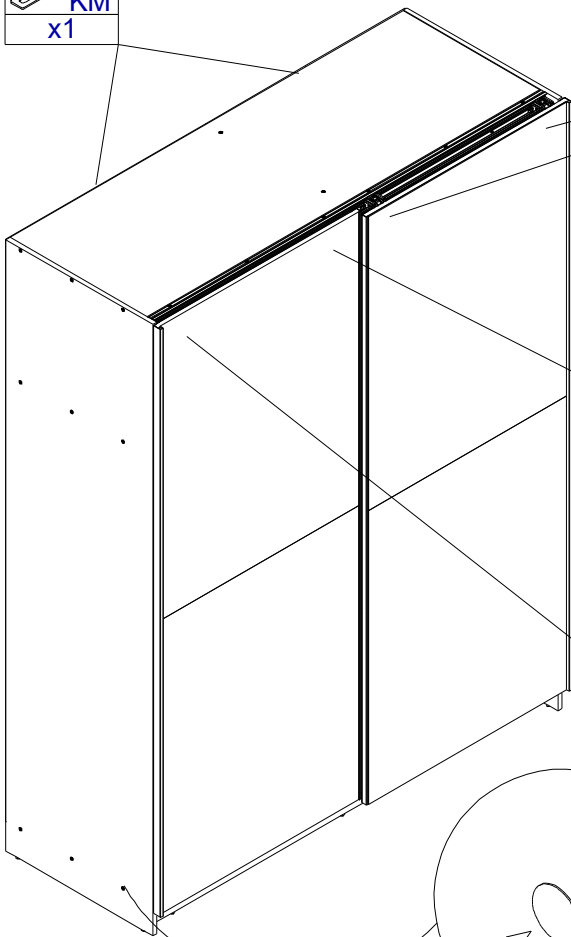
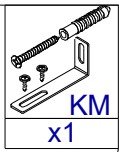

lock

X3
x36

lock

lock

1

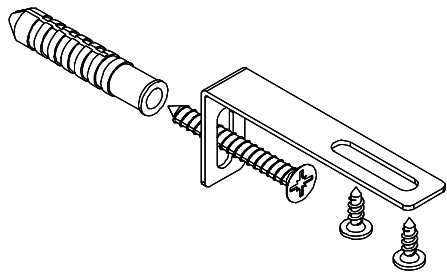

Uwaga . Upozornini. Achtung . Attention . Caution Firyelem . Attenzione . Opgelet . ВНИМАНИЕ . Atentie . Upozornenie . Dikkat . Uppmärksamhet . Uppmärksamhet . Pozor . Pažnja

PL	Mocowanie do ściany jest jednocześnie zabezpieczeniem przed przewróceniem - konieczne zamontować! Do niektórych rodzajów ścian konieczne zastosować specjalne kołki mocujące.	I	Il fissaggio alla parete serve da protezione anti-ribaltamento - attaccarla assolutamente! Per alcune strutture di parete può essere necessario un tassello speciale!
CZ	Montáž na stěnu slouží jako ochrana proti převrnutí - bezpodmínečně umístěte! U některých typů stěn může být zapotřebí speciální hmoždinka!	NL	Bevestiging aan de muur dient als kantelbescherming - zeker en vast bevestigen! Bij enkele muurtypes is een speciale plug misschien vereist!
D	Wandbefestigung dient als Kippschutz - unbedingt anbringen! Bei einigen Wandtypen kann ein Spezialdübel erforderlich sein!	RU	Крепление к стене также является защитой от опрокидывания - обязательно установите! Для некоторых типов стен необходимо использовать специальные крепежные штифты.
GB	The wall fastening serves to prevent tipping - be absolutely sure to mount it! For certain wall types, a special wall plug may be necessary!	RO	Sistemul de fixare la perete serve și ca protecție la răsturnare - de montat obligatoriu! Pentru unele tipuri de pereți este posibil să fie necesar un diblu special!
F	La fixation murale sert de protection contre le basculement - à installer impérativement ! Pour certains types de murs il faut des chevilles spéciales !	SK	Upevnenie na stenu slúži ako ochrana proti prevráteniu - bezpodmienečne použite! Pre niektoré druhy stien môže byť potrebná špeciálna hmoždinka!
HU	A termékét a falhoz keletve rögzíteni, különben az felborulhat! Egyes fal típusoknál speciális tiplit kell használni!	TR	Duvardaki sabitleme, devrilmeye karşı, bir emniyet tedbiridir ve mutlaka monte edilmelidir! Bazı duvar tiplerinde bunun için özel bir dübel gereklidir!
SE	Att fästa den på väggen är också ett skydd mot att välta - se till att installera det! För vissa typer av väggar är det nödvändigt att använda speciella monteringsstift.	SLO	Pritrđitev na steno je tudi zaščita pred prevrnitvijo - obvezno jo namestite! Za nekatere vrste sten je treba uporabiti posebne pritrđilne zatiče.
HR	Pričvršćivanje na zid je ujedno i zaštita od prevrtanja - obavezno ga postavite! Za neke vrste zidova potrebno je koristiti posebne pri čvršćne igle.		

2a

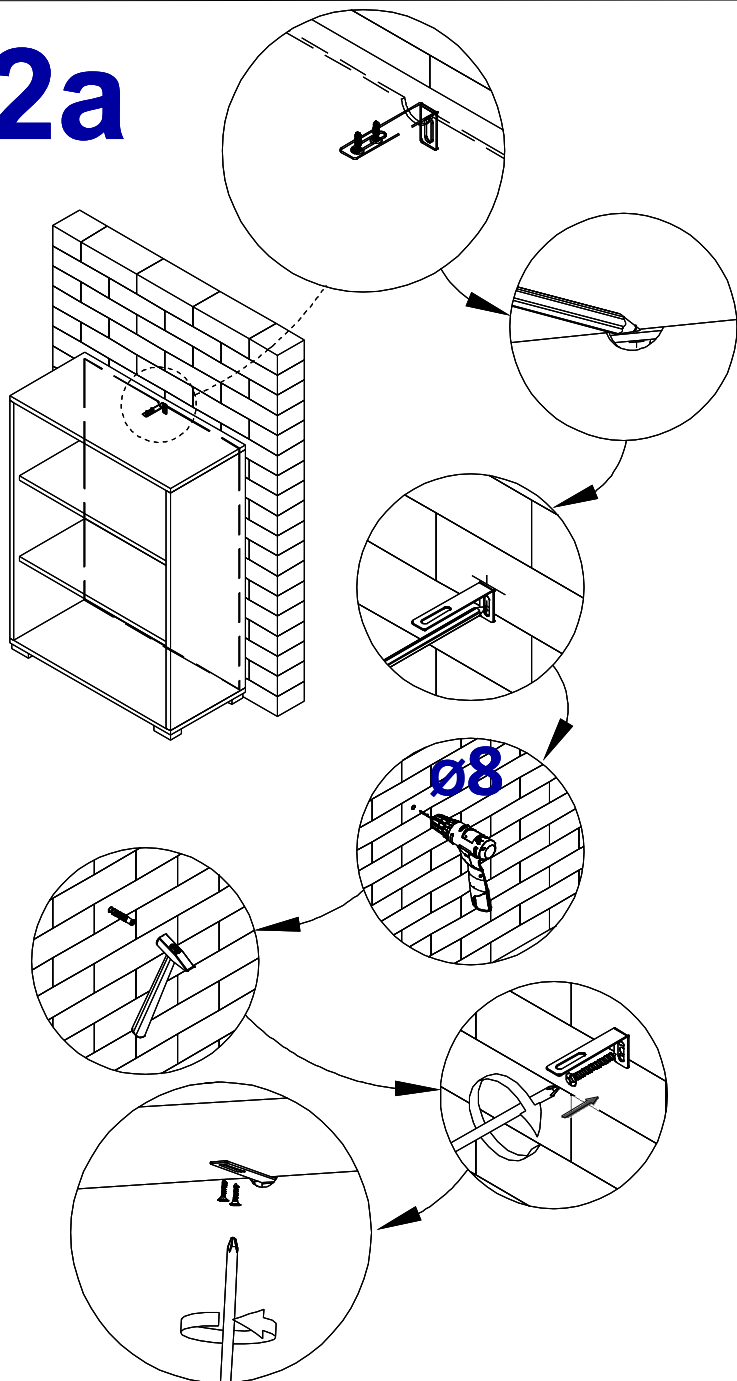

2b

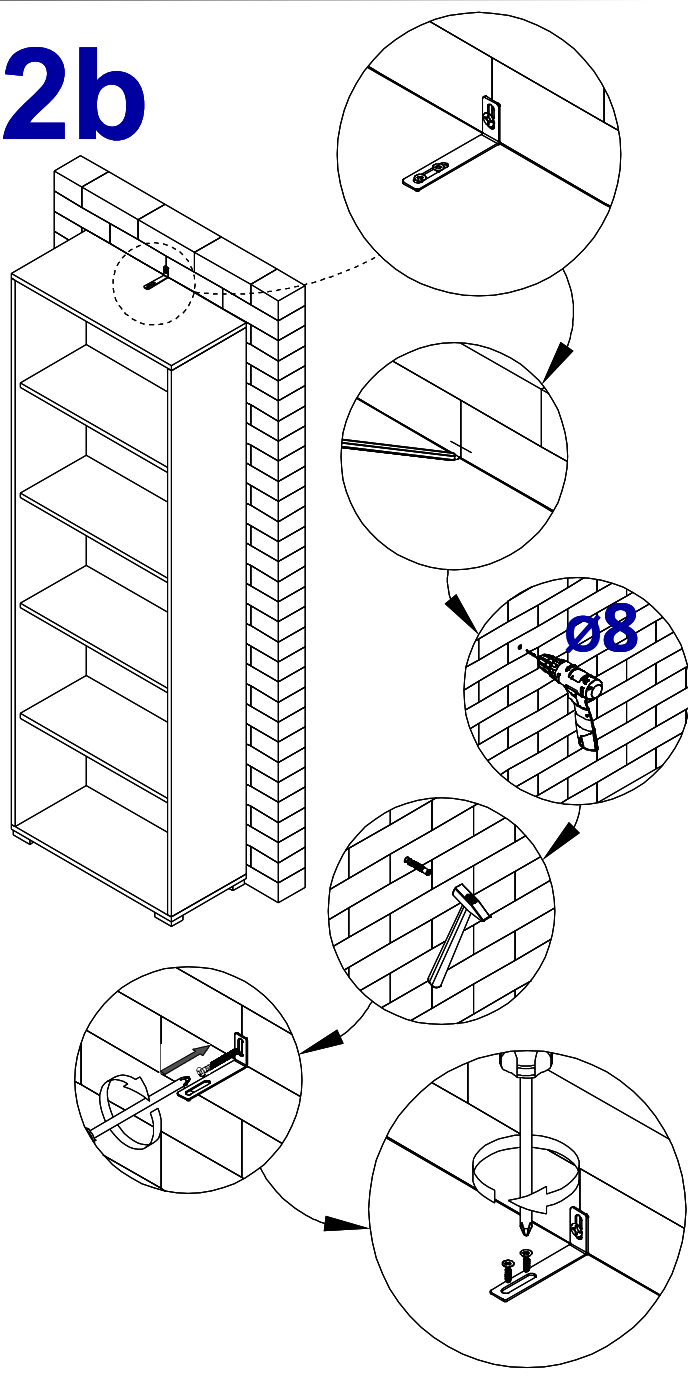

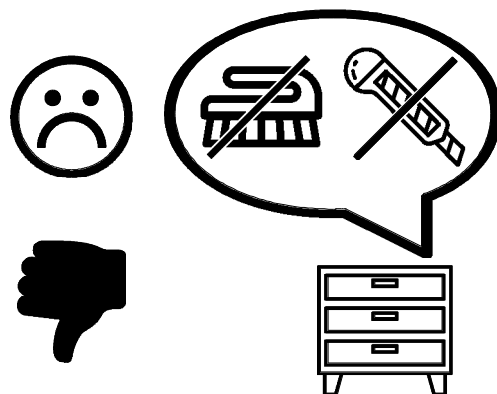
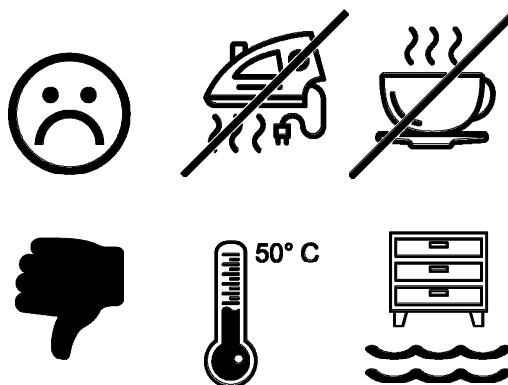
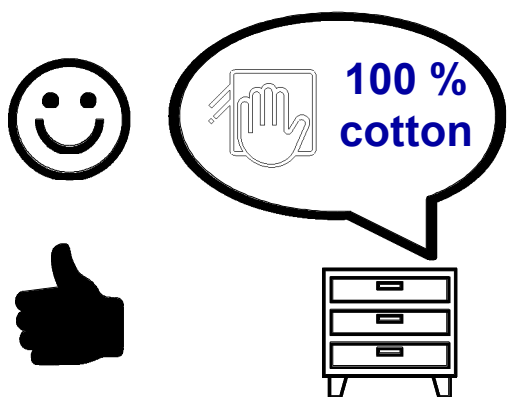

FR

Donnez ou recyclez
vos meubles.



ou



ou



Association

Magasin

Déchèterie

<https://quefairedemesdechets.fr>



CARTON
+ PLASTIQUE
+ NOTICE



Séparez les éléments
avant de trier