

DUSK . COM

Range Name: ISLA
Product Dimensions: L105 x W56 x H190(cm)

LIVING BEDROOM DINING

2 Door 2 Drawer Wardrobe

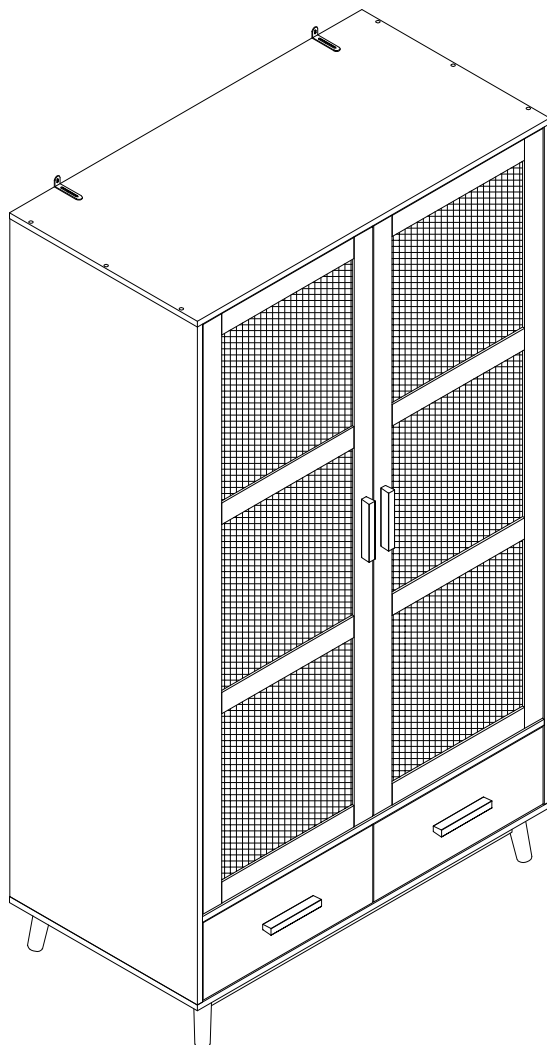

THIS INSTRUCTION BOOKLET CONTAINS IMPORTANT SAFETY INFORMATION
PLEASE READ AND KEEP FOR FUTURE REFERENCE.

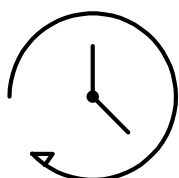

60 minutes approx
assembly time

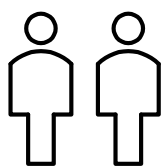

Two adults
assembly required

This product is intended for domestic use only , not for commercial purposes.

Page 1

Important

Assembly Tip

Before you begin, we advise laying everything out on a clean and soft level surface to avoid damaging the unit or your floor, It's best to identify all of the parts and fittings to build your Wardrobe, and to familiarise yourself with all of the parts and fittings before building.

Top Tip

We recommend that you build your new Wardrobe in the room you'd like it to be located. This will help prevent any risk of damage to the product whilst moving it.

Safety and Care

1. It's important to ensure children and animals are kept away from the assembly area, as there are small components used in this Wardrobe which could present a choking hazard. All plastic and wrapping materials should also be kept away from children and animals to prevent any risk of suffocation.
2. Do not stand on your product.
3. Always use the item on firm level ground, ensuring all legs remain in contact with the ground.
4. Place heaviest items in the lowest drawers.
5. Do not set TV or other heavy objects on top of the product.
6. Children should always be under supervision whilst using this product. Never allow children to climb on the drawers.
7. Never keep more than one drawer open at the same time.
8. The installation of an anti tipping kit to secure your furniture is strongly suggested.
9. Serious or fatal crushing injuries can occur from tipping furniture.

Help and Support

Please contact our customer service team on 0113 519 0311 if you have any questions or issues with your purchase.

Recycling

Please ensure that packaging is disposed of in a safe and environmentally friendly way, and recycle where possible. Please keep your assembly instructions safe to refer back to in the future.

Care and Maintenance

1. Only clean using a damp cloth, do not use bleach or abrasive cleaners as they may damage the finish over time.
3. Do not scrub or rub the surface when cleaning.
2. Do not use a very wet cloth or allow any liquid to contact with the veneer for a long period of time. Wipe any spillage immediately. Absorption can cause wood to warp or finishes to de-laminate.
4. Do not drag the Wardrobe when moving, lift it off the floor instead.
5. Use a placemat or a coaster when putting hot items (e.g. hot drinks and dishes) on the wood surface.
6. It is not recommended to place the item next to sources of heat such as radiators, fires or directly exposed to sunlight. This may cause the wood to crack, split or fade due to the change of the humidity and temperature.
7. Wood will mellow and change colour over time, we recommend that ornaments and items placed on the surface to be moved regularly to prevent uneven mellowing.
8. Regularly check all fixings to ensure none have come loose. Re-tighten if necessary,
9. Avoid sharp items such as a screwdriver or any pointy tools. Page 2

Parts checklist

Please check you have all the parts listed below with your product:
Do not discard any of the packaging until you have checked that you have all the parts and the pack of fixings.

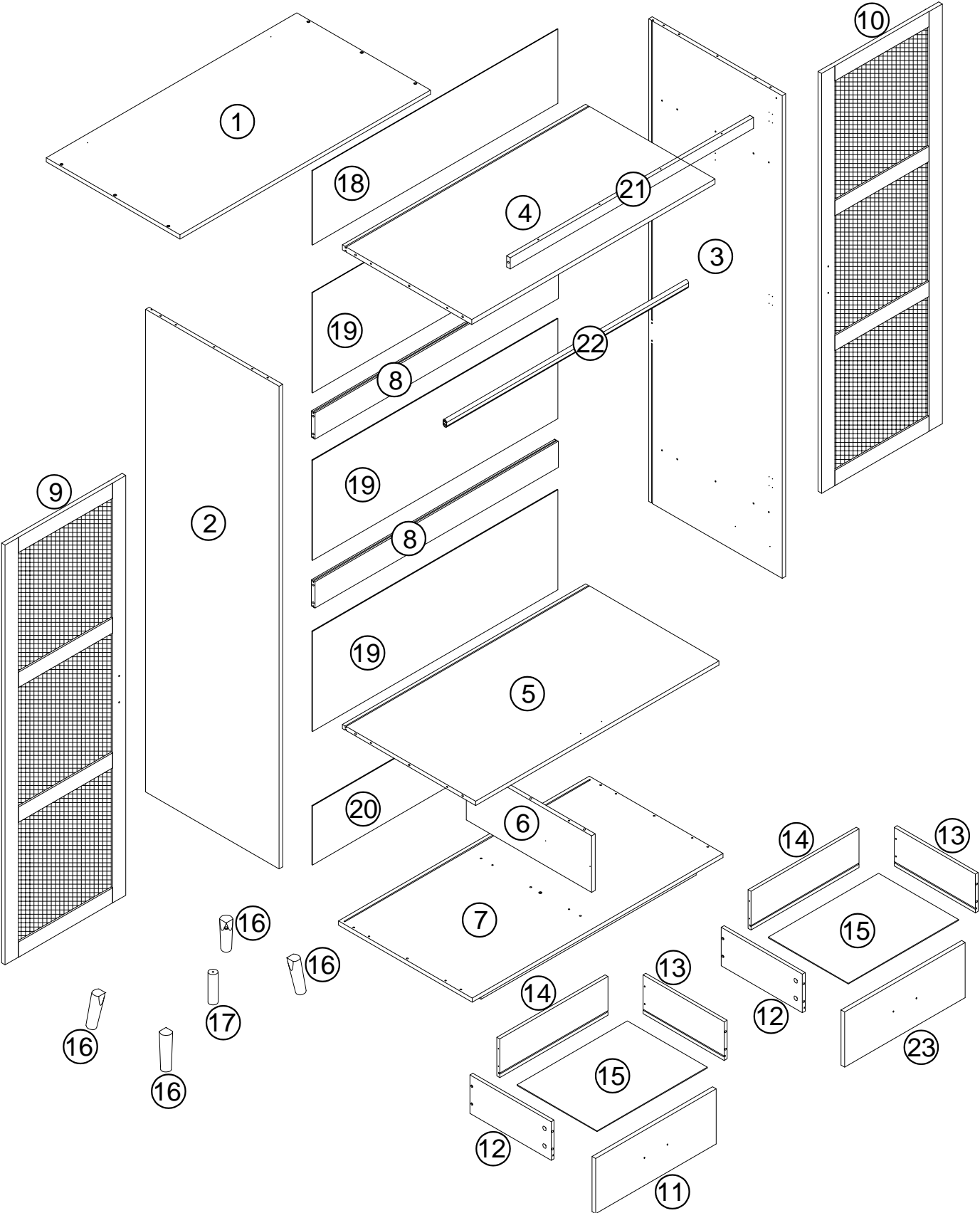

Fittings checklist

Please check you have all the fittings listed below with your product:

 <p>A 36mm cam bolt x33pcs (+3 extra)</p>	 <p>B M15x9.5mm cam x33pcs (+3 extra)</p>	 <p>C M6x30mm Wood dowel x20pcs (+2 extra)</p>
 <p>D M4x35mm Screw x14pcs (+1 extra)</p>	 <p>E M3x12mm Screw x24pcs (+3 extra)</p>	 <p>F L wall fixing x2pcs</p>
 <p>G M4x12mm Screw x2pcs</p>	 <p>H 30mm Wall Plug x2pcs</p>	 <p>I M4x30mm Screw x8pcs (+1 extra)</p>
 <p>J Runner x4pcs</p>	 <p>K M6x50mm Screw x4pcs</p>	 <p>L Metal plate x4pcs</p>
 <p>M Metal plate x4pcs</p>	 <p>N L fitting x1pc</p>	 <p>O Felt pad x4pcs</p>
 <p>P Back bracket x24pcs (+2 extra)</p>	 <p>Q M3x14mm Screw x28pcs (+2 extra)</p>	 <p>R Adjustment feet x1pc</p>
 <p>S Handle x4pcs</p>	 <p>T Sticker x31pcs (+3 extra)</p>	 <p>U M7x50mm Screw x16pcs (+1 extra)</p>

Bolt Length Ruler:

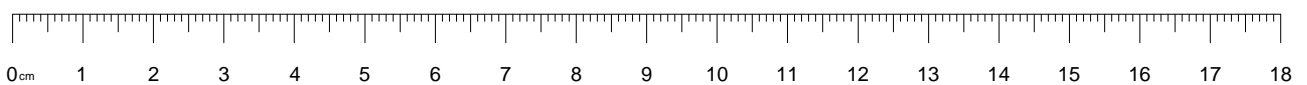

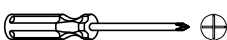

Tool required



Crosshead Screwdriver (not provided)

Fittings checklist

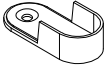
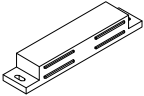
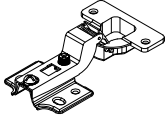
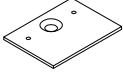
Please check you have all the fittings listed below with your product:

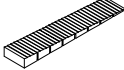
 (V) Clothes rail support fitting x2pcs	 (W) Magnet x2pcs	 (X) Hinge x6pcs
 (Y) Metal piece x4pcs	 (Z) M4x14mm Screw x36pcs (+4 extra)	 (AA) Leveller x2pcs

Bolt Length Ruler:

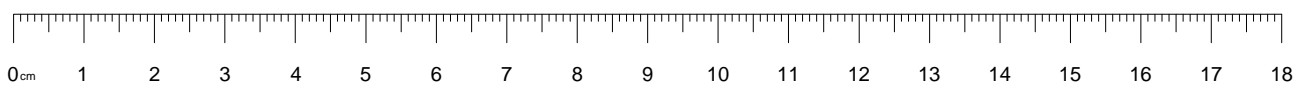

Tool required



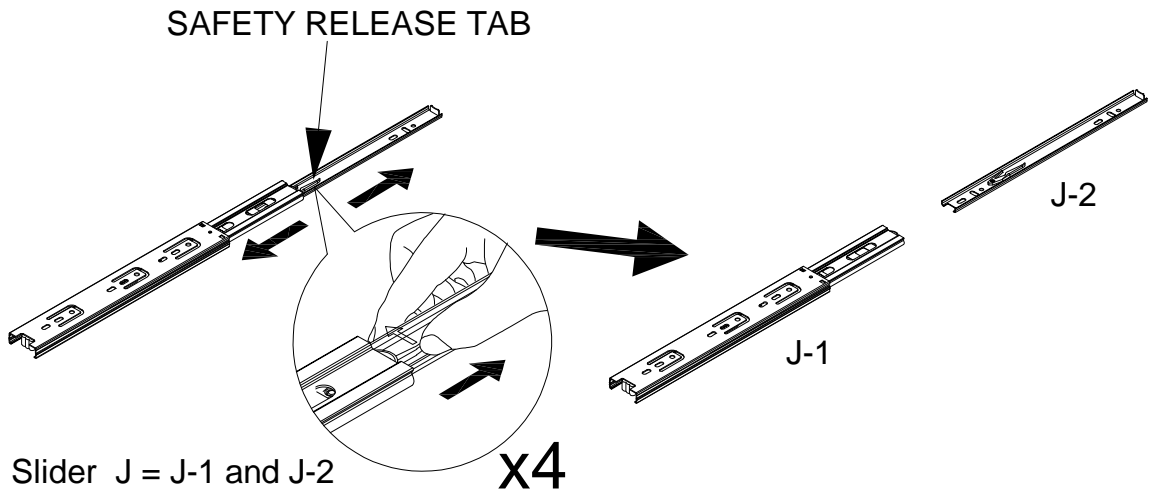
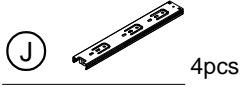

Step 1

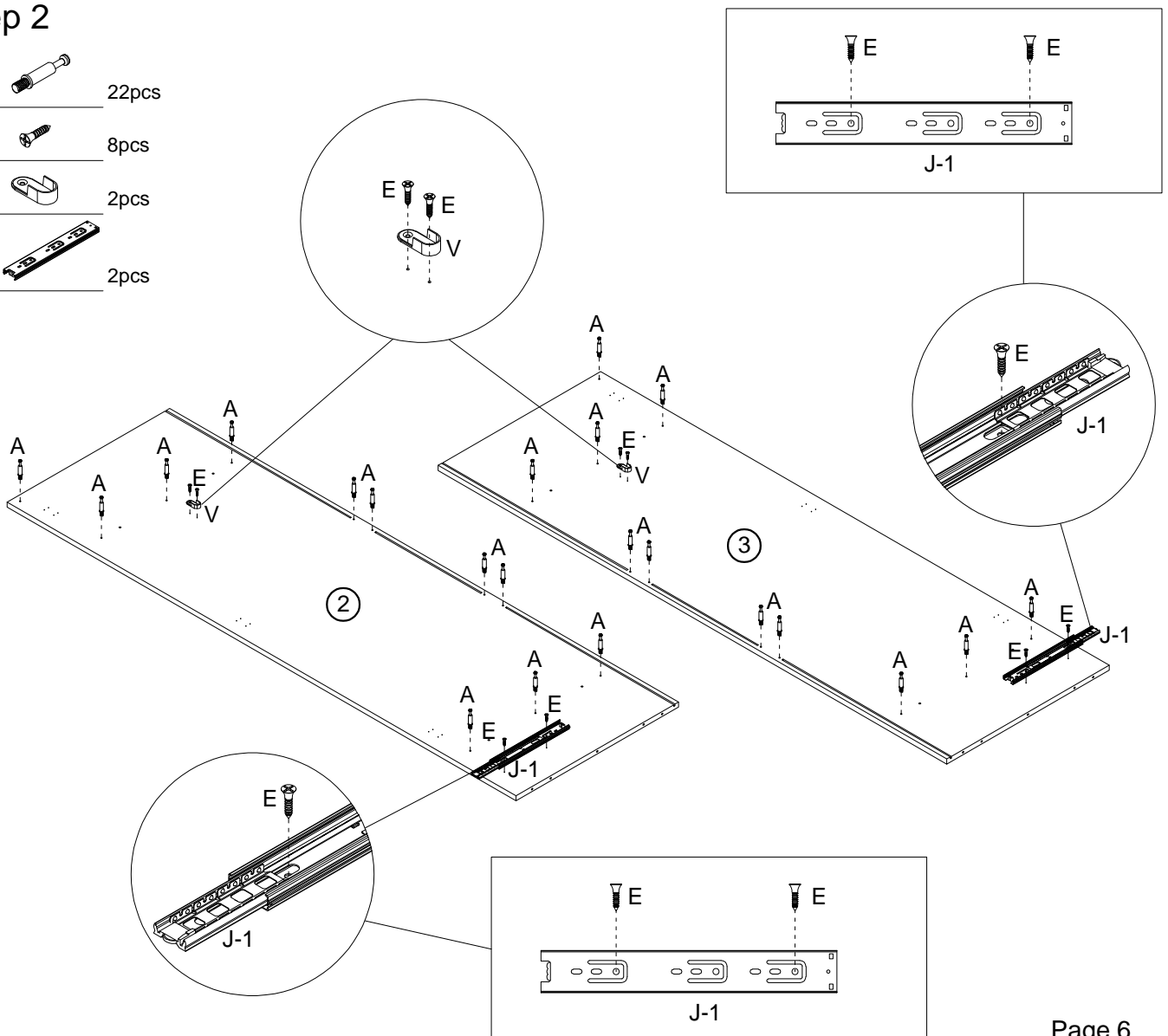
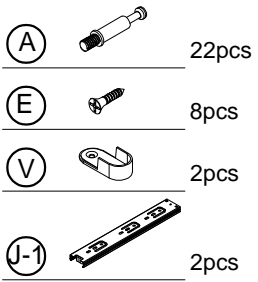

Step 2



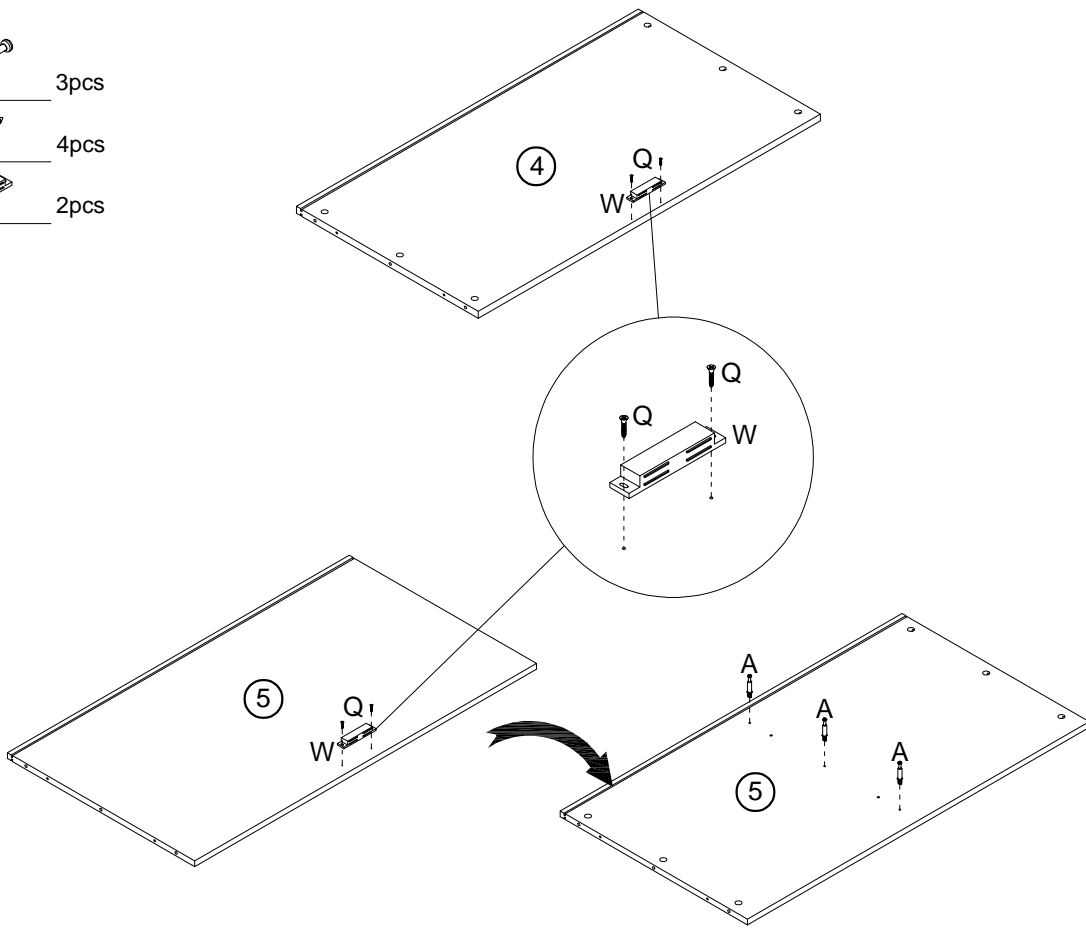

Step 3

- Ⓐ  3pcs
- Ⓚ  4pcs
- Ⓦ  2pcs



Step 4

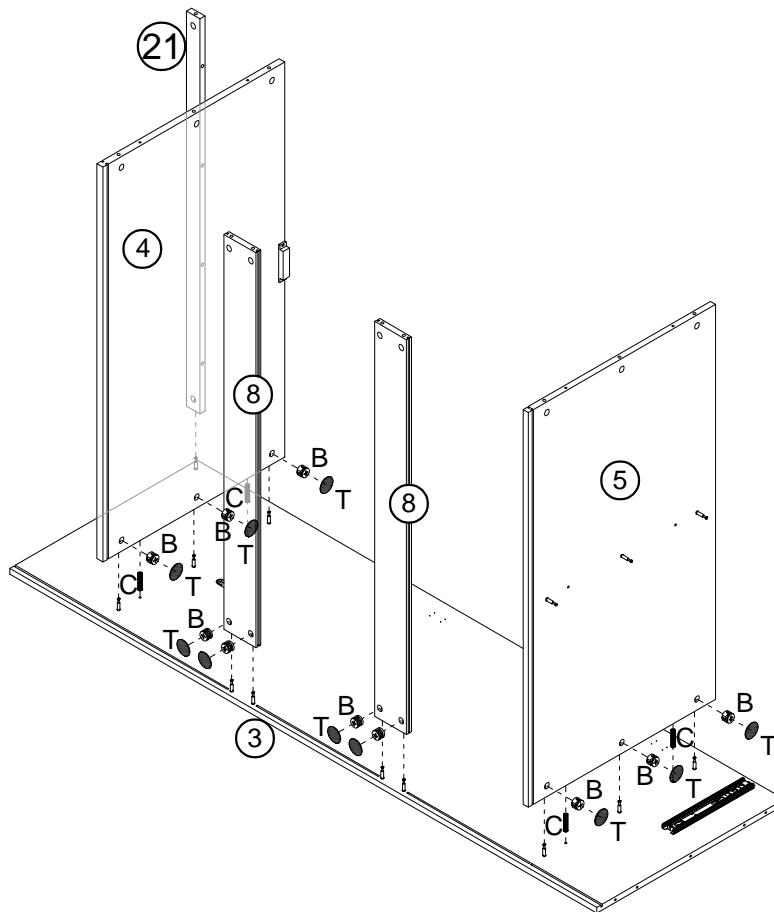

- Ⓑ  11pcs
- Ⓒ  4pcs
- Ⓓ  10pcs

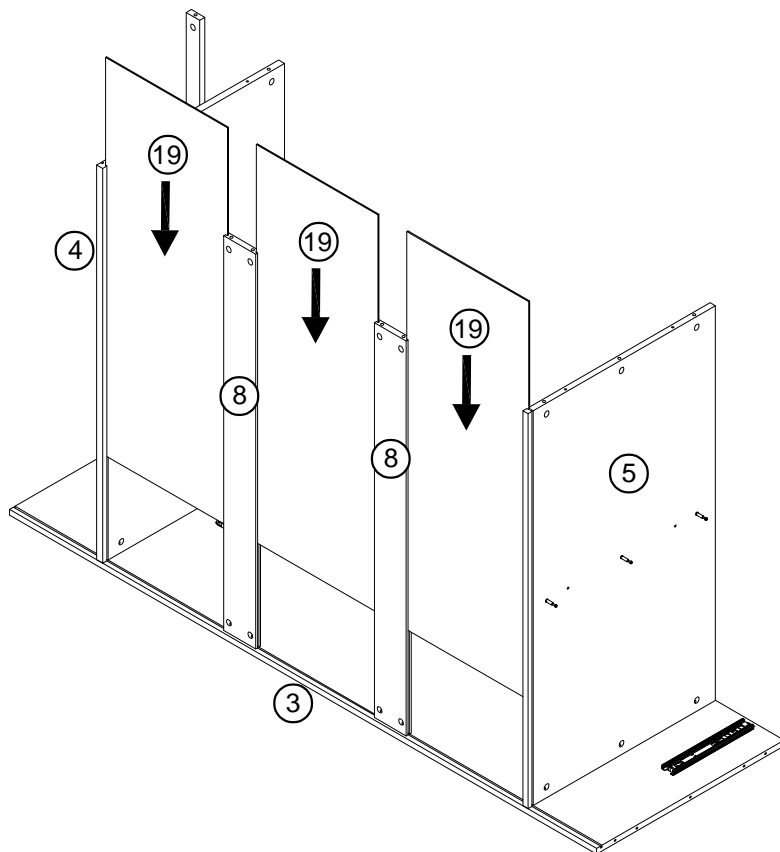

Step 5



Step 6

- (B)  11pcs
- (C)  4pcs
- (T)  10pcs

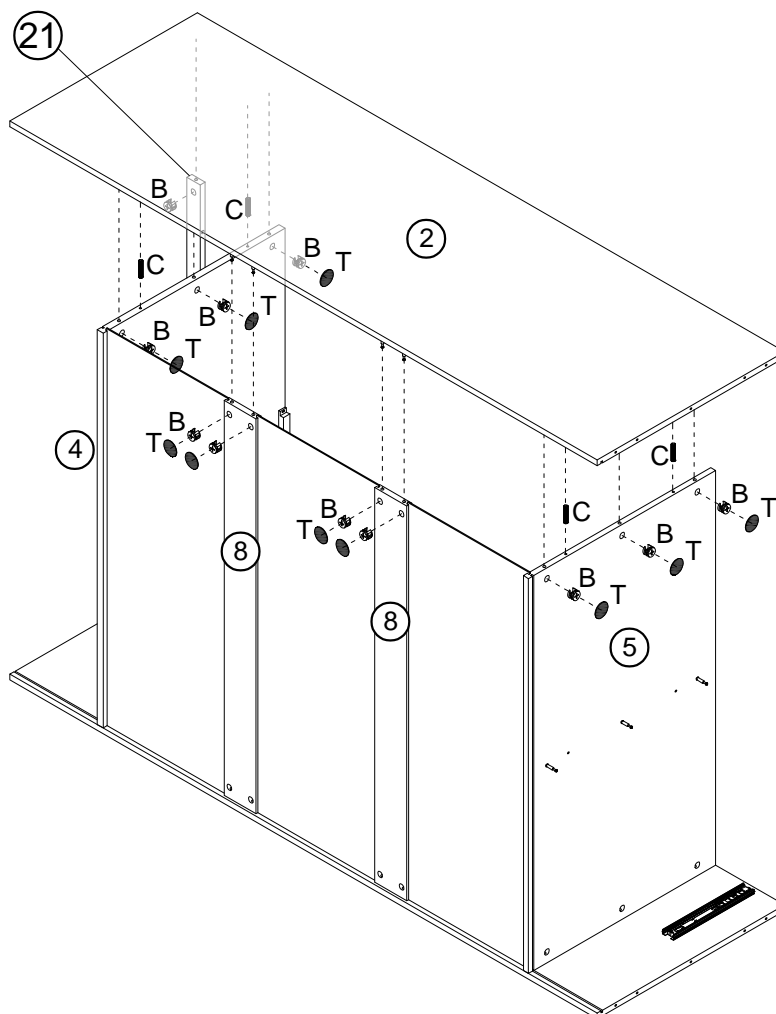

Step 7

Ⓔ 4pcs

Ⓙ-1 2pcs

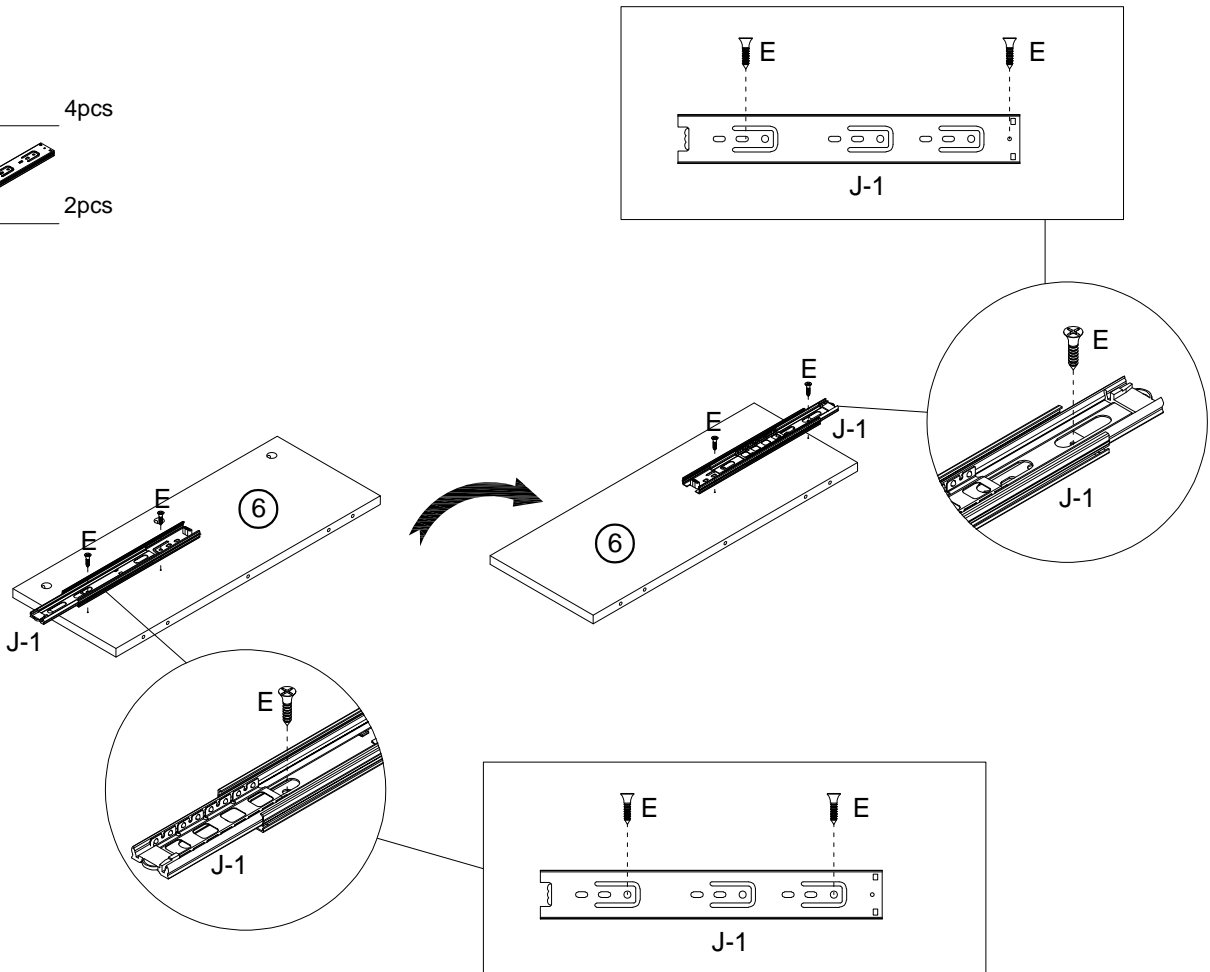

Step 8

Ⓑ 3pcs

Ⓒ 2pcs

Ⓓ 3pcs

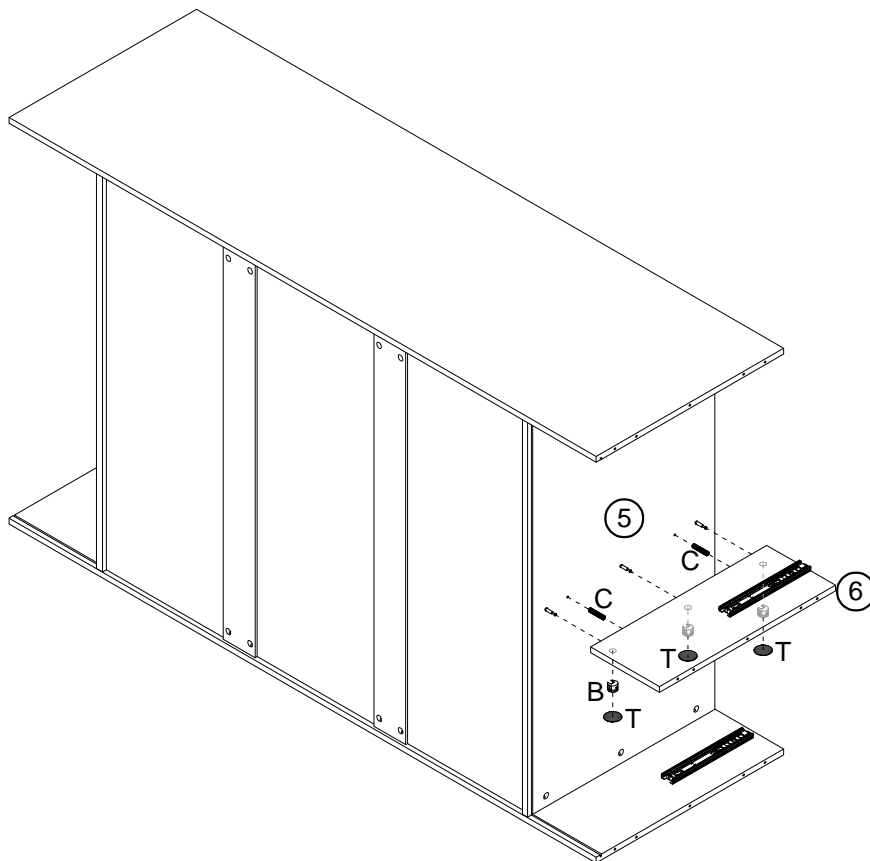

Step 9

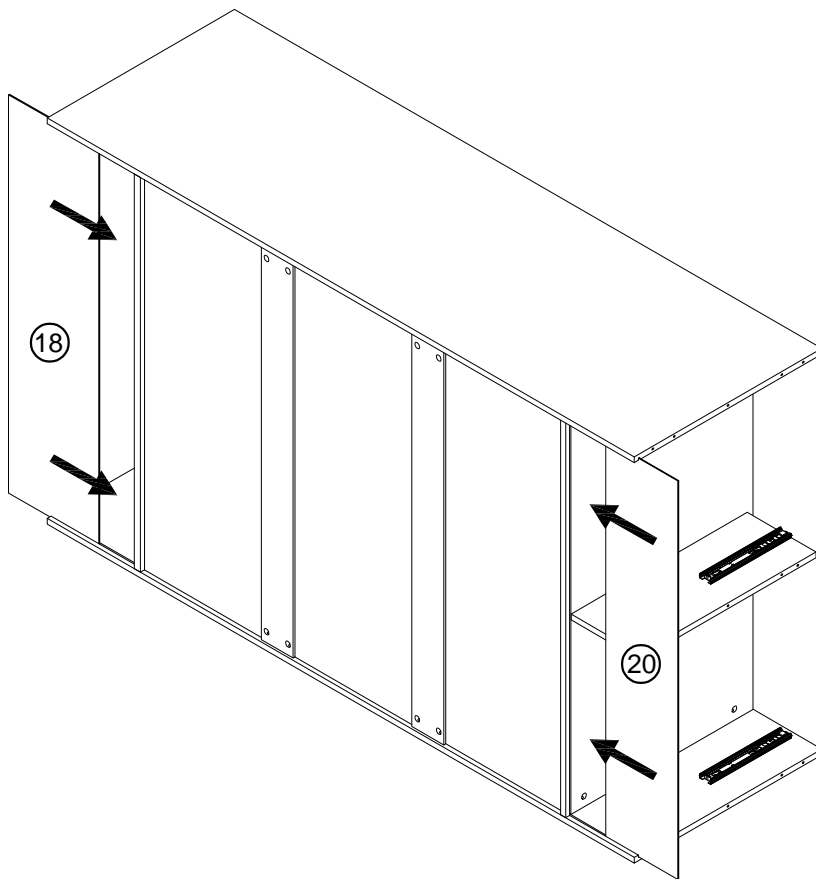

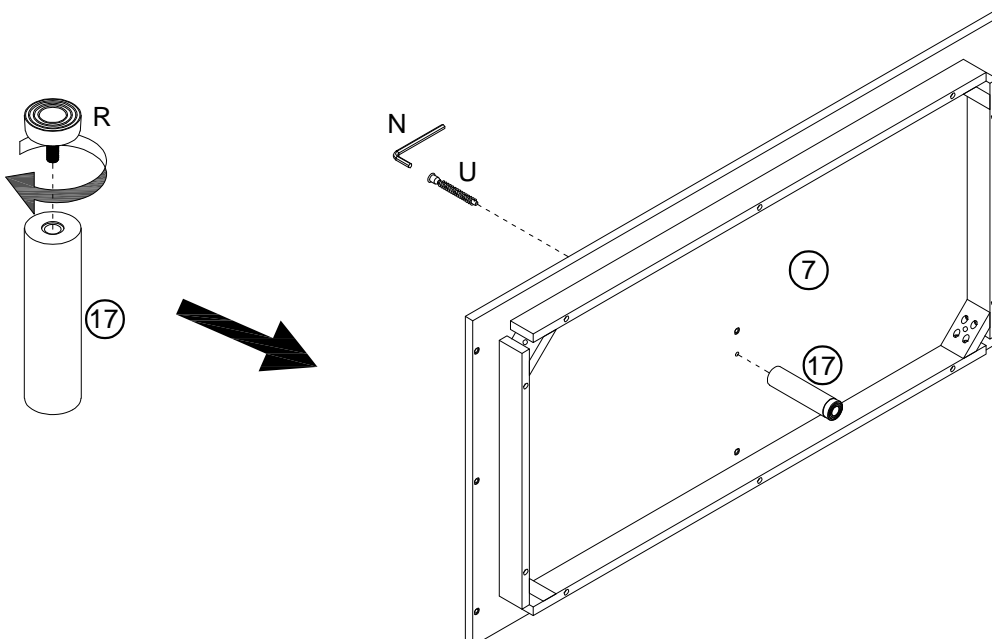

Step 10

- Ⓝ 1pc
- Ⓡ 1pc
- Ⓤ 1pc





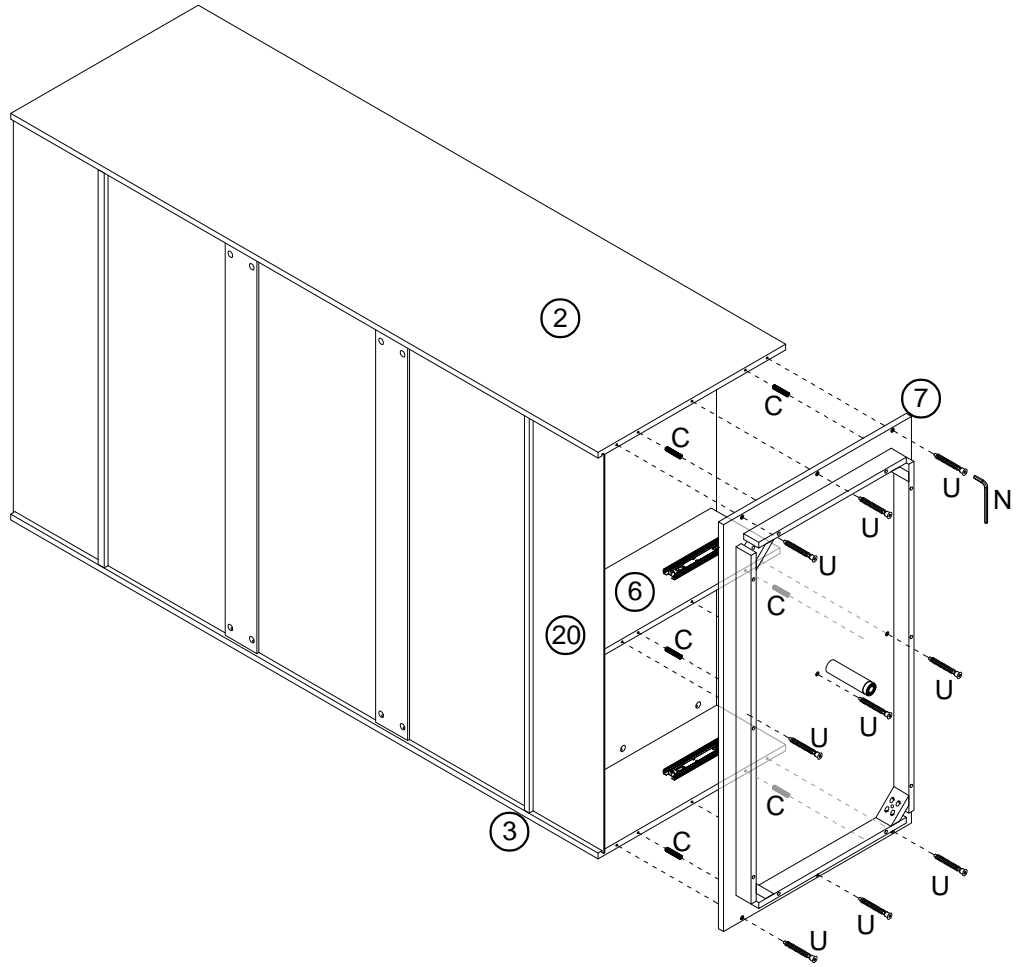

Step 11

- Ⓒ  6pcs
- ⒰  9pcs



Step 12

- Ⓐ  4pcs
- Ⓕ  4pcs
- Ⓖ  4pcs
- Ⓗ  4pcs

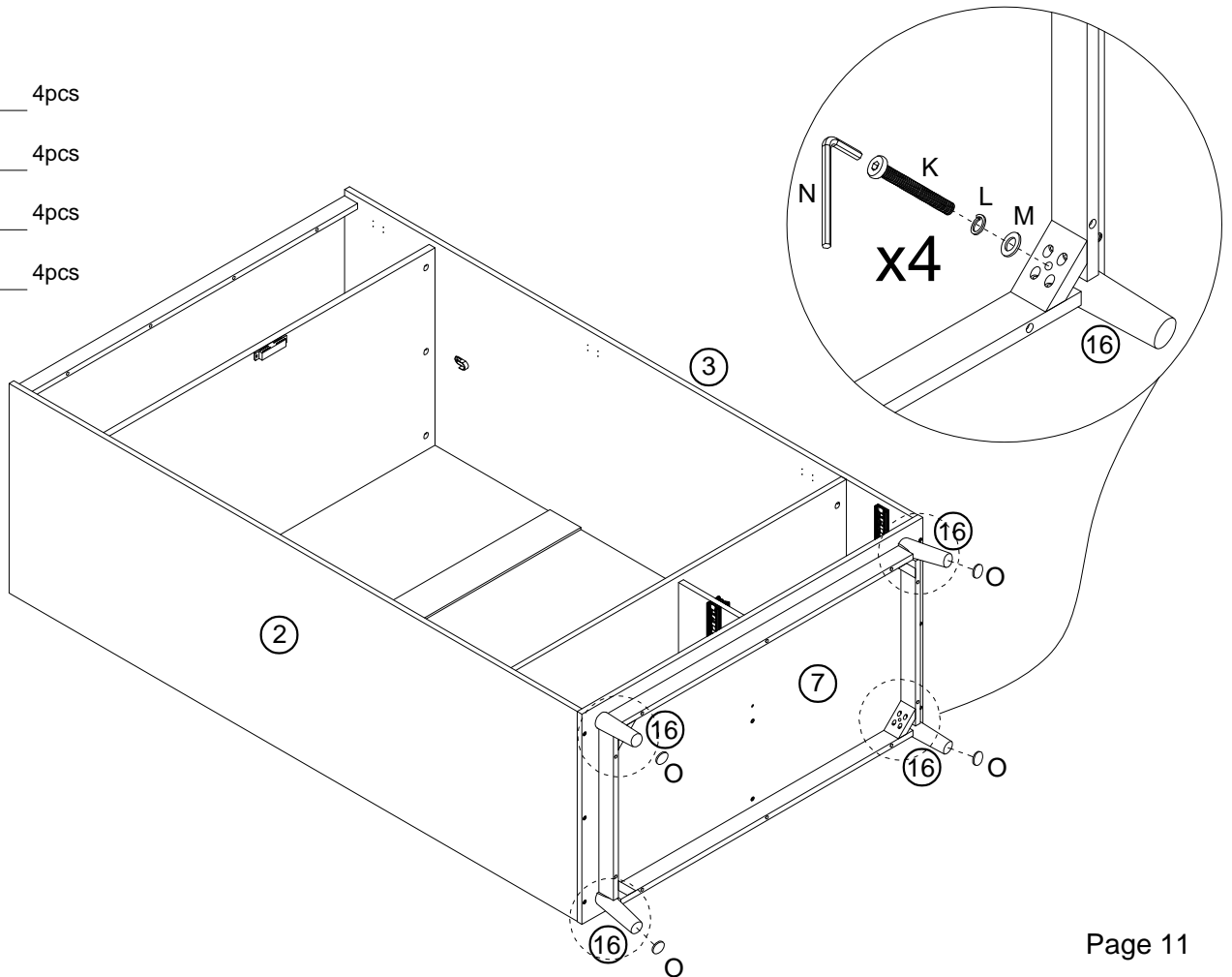

Step 13

Ⓒ 4pcs

Ⓓ 4pcs

Ⓕ 2pcs

Ⓖ 2pcs



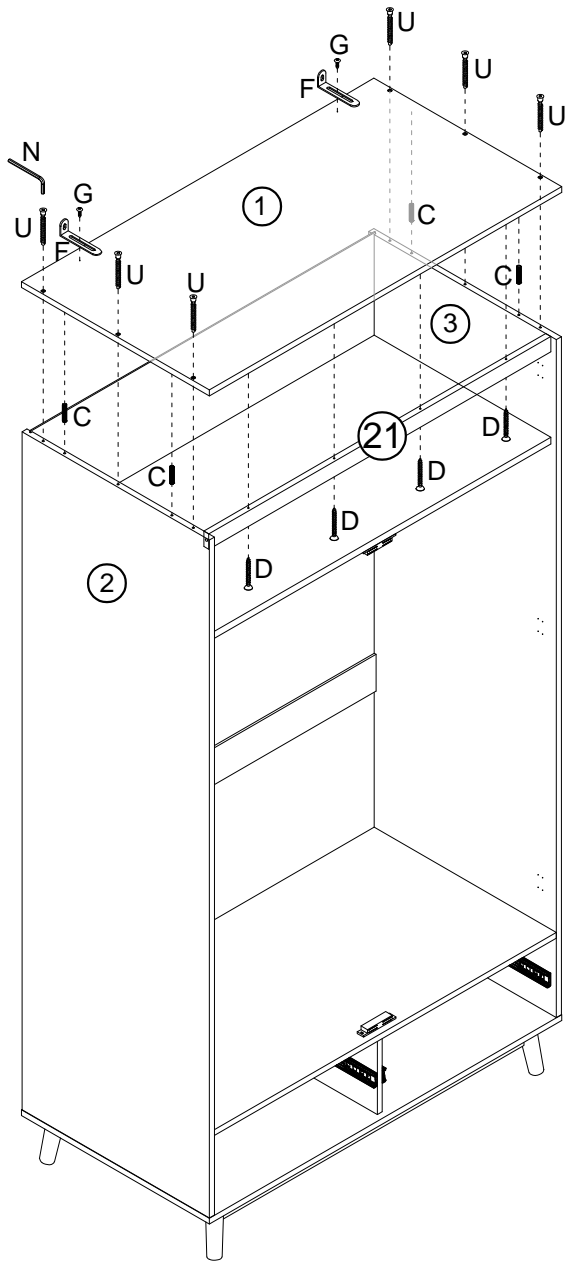

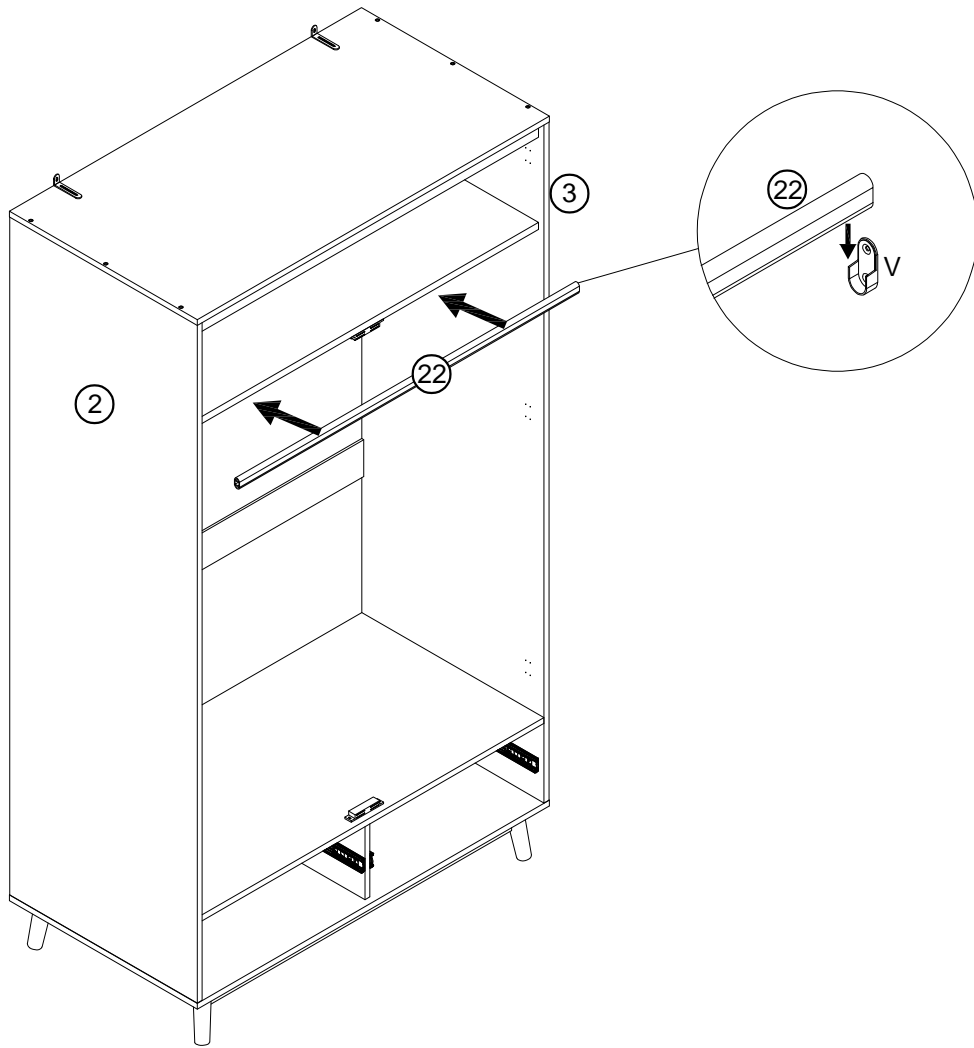

⒰ 6pcs



Step 14



Step 15

- (E)  4pcs
- (I)  4pcs
- (S)  2pcs
- (X)  6pcs
- (Y)  4pcs
- (Z)  12pcs

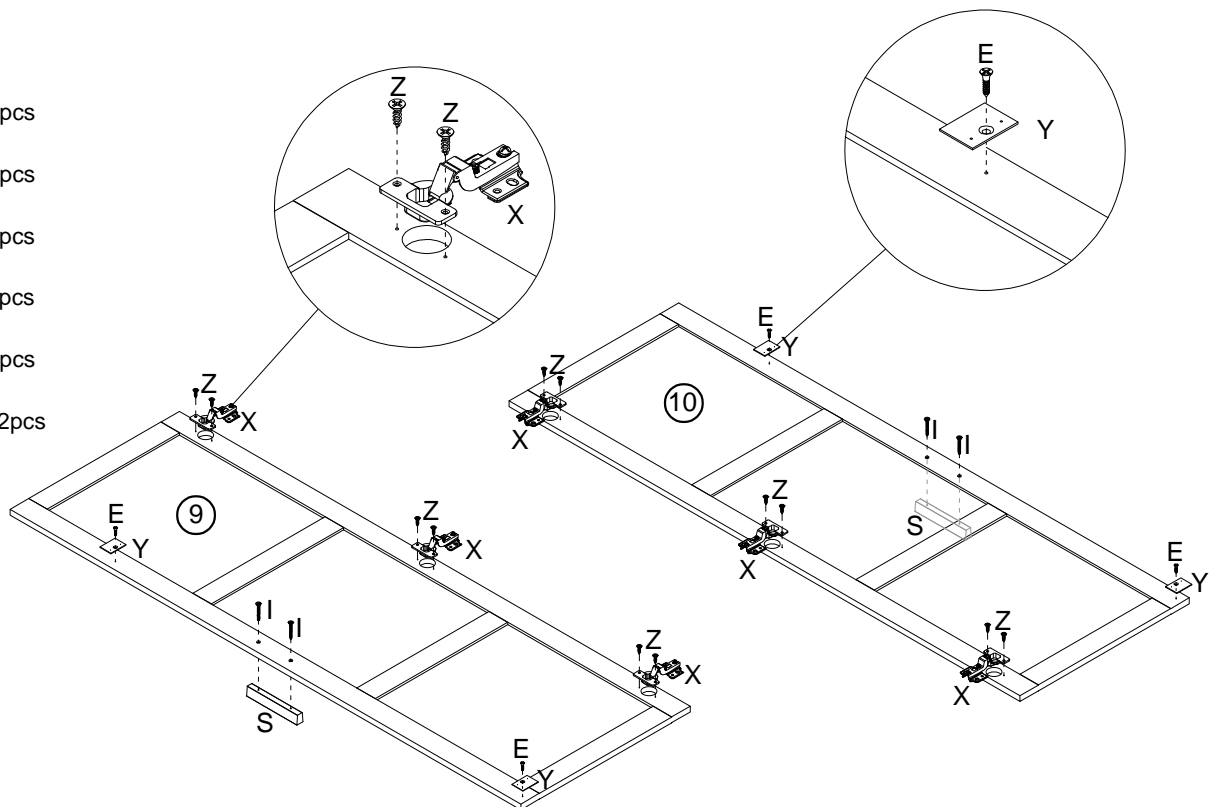

Step 16

Ⓩ  24pcs

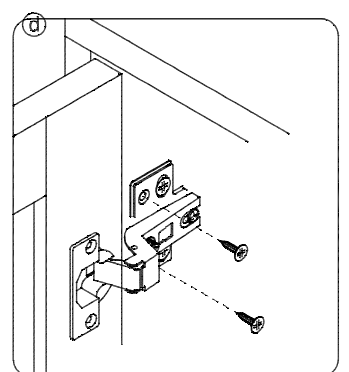
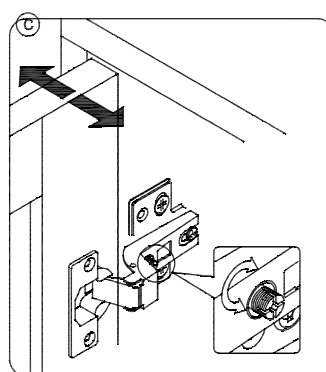
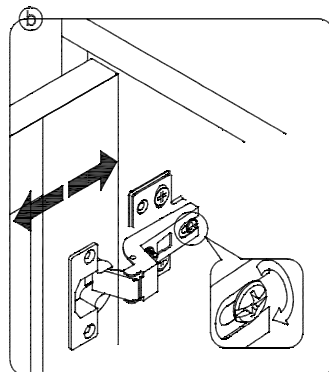
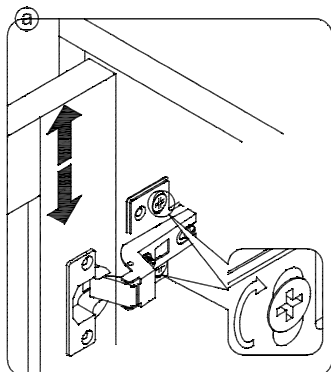
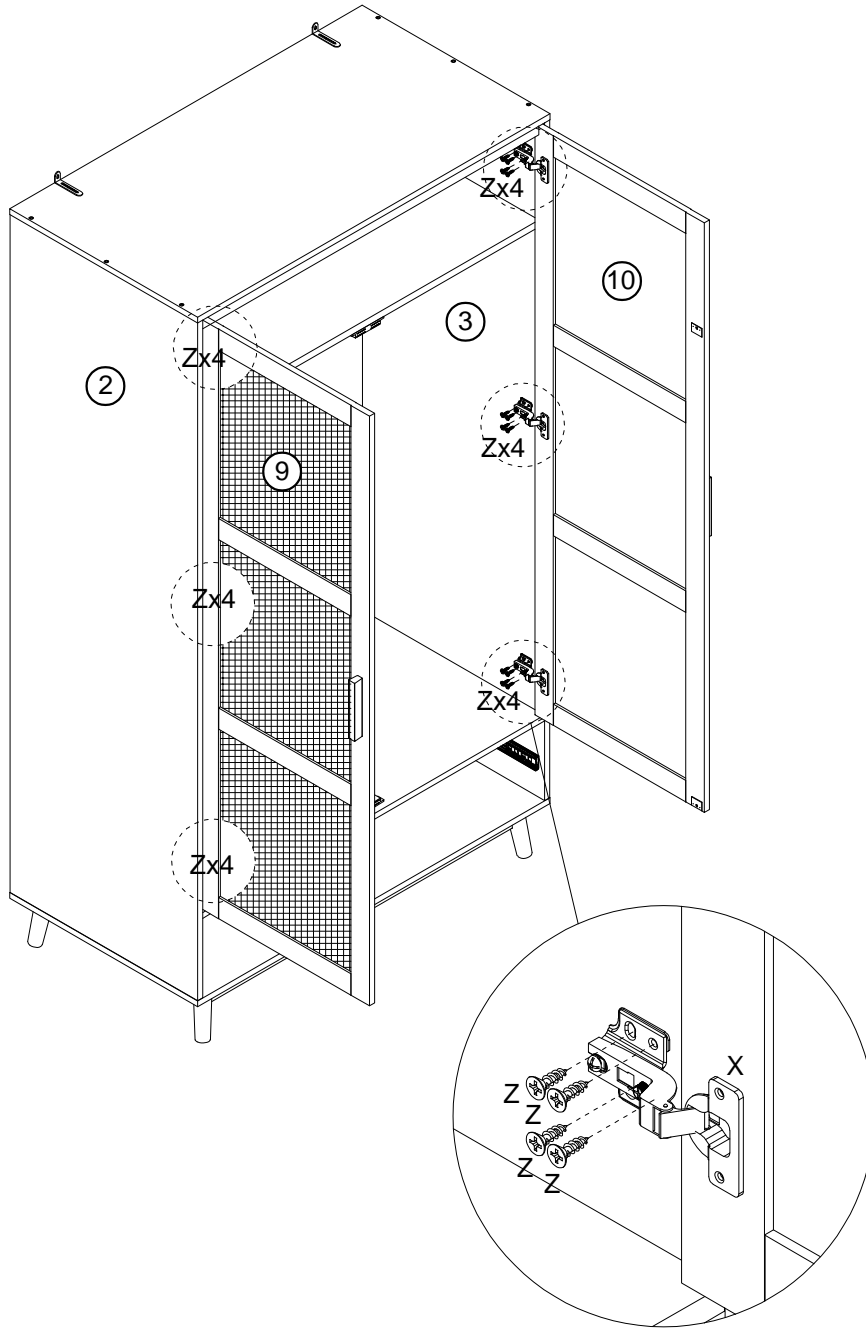

Step 17

Ⓔ 8pcs

Ⓙ-2 4pcs

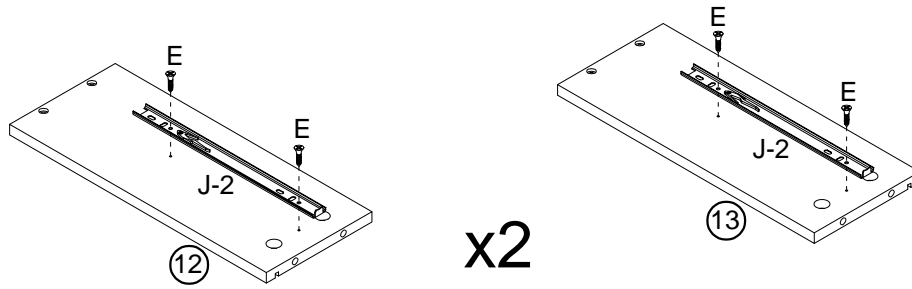
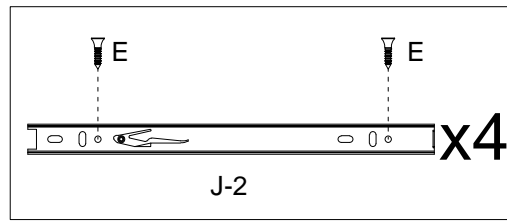



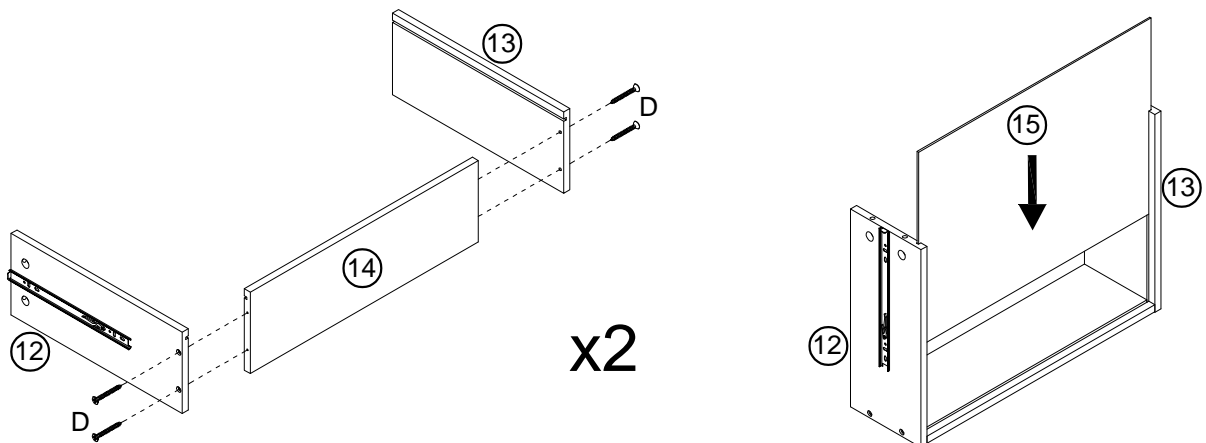

Step 18

Ⓓ 8pcs



Step 19

- (A)  8pcs
- (B)  8pcs
- (I)  4pcs
- (S)  2pcs
- (T)  8pcs

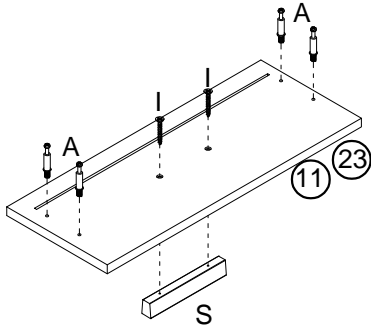

x2

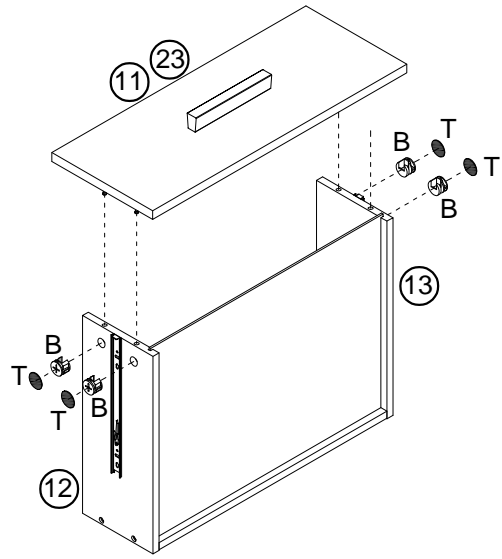

Step 20

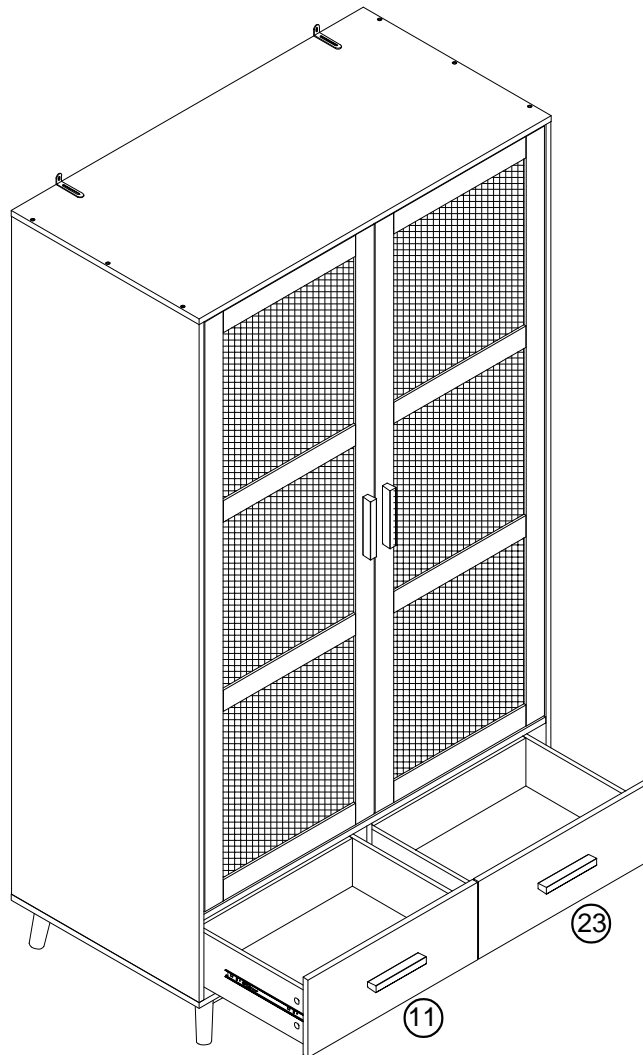
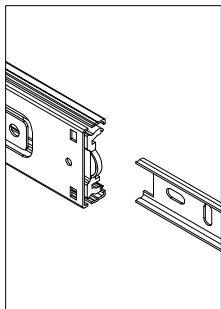
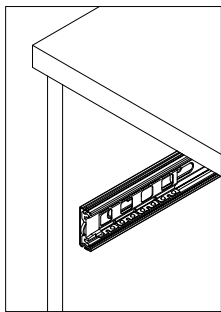

Step 21

Ⓟ  24pcs

Ⓠ  24pcs

Manually adjust the frame slightly to ensure the drawers are in the correct position, even and parallel before attaching the plastic buckles

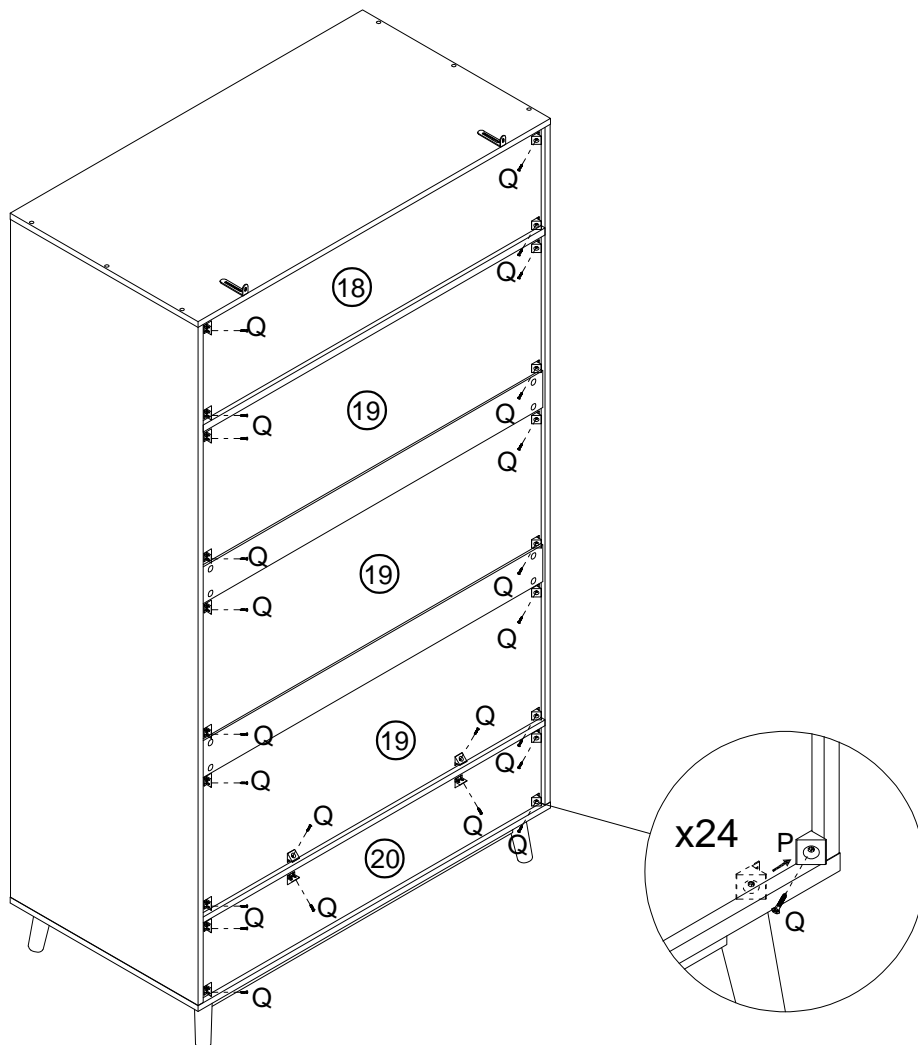

Step 22

Ⓓ  2pcs

Ⓗ  2pcs

ⒶⒶ  2pcs

