

DUSK.COM

LIVING | BEDROOM | DINING

Hampshire Three Seater

Box dimensions: W210 x D92 x H57 (cm)

Product dimension: W207.5 x D90 x H86 (cm)

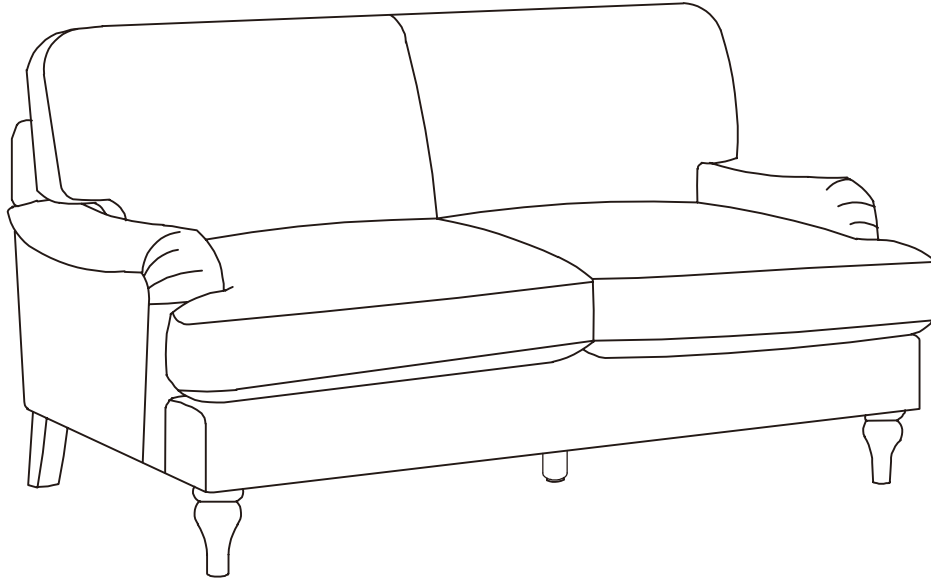

THIS INSTRUCTION BOOKLET CONTAINS IMPORTANT SAFETY INFORMATION.
PLEASE READ AND KEEP FOR FUTURE REFERENCE.



20 minutes approx
assembly time

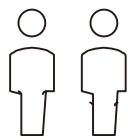

Two adults
assembly required

This product is intended for domestic use only, not for commercial purposes.

P-1-8
V-2.0

Parts checklist

Please check you have all the parts listed below with your product:



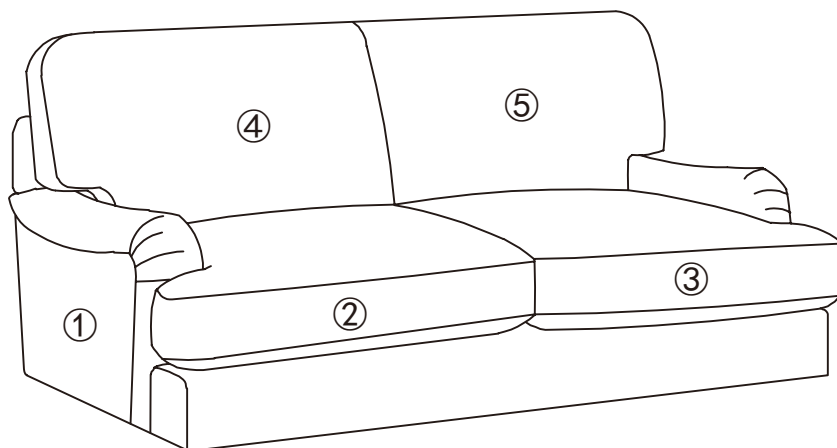



Do not discard any of the packaging until you have checked that you have all the parts and the pack of fixings.



NO.	Parts List	QTY
1	Frame	1pc
2	Left Seat Cushion	1pc
3	Right Seat Cushion	1pc
4	Left Back Pillow	1pc
5	Right Back Pillow	1pc

Fittings checklist

Please check you have all the fittings listed below with your product:

<p>A</p> 	<p>B</p> 	<p>C</p> 	<p>D</p> 	<p>E</p> 
<p>Bolt M8 x 65mm</p>	<p>M5 Allen key</p>	<p>Front Leg (H150mm)</p>	<p>Plastic washer Dia 48*3mm</p>	<p>Rear leg (H150mm)</p>
<p>2</p>	<p>1</p>	<p>2</p>	<p>2</p>	<p>2</p>
<p>F</p> 	<p>G</p> 			
<p>Wood chipping M8x40mm</p>	<p>Medium foot</p>			
<p>2</p>	<p>1</p>			

Step 1 Open the box to access the hardware.

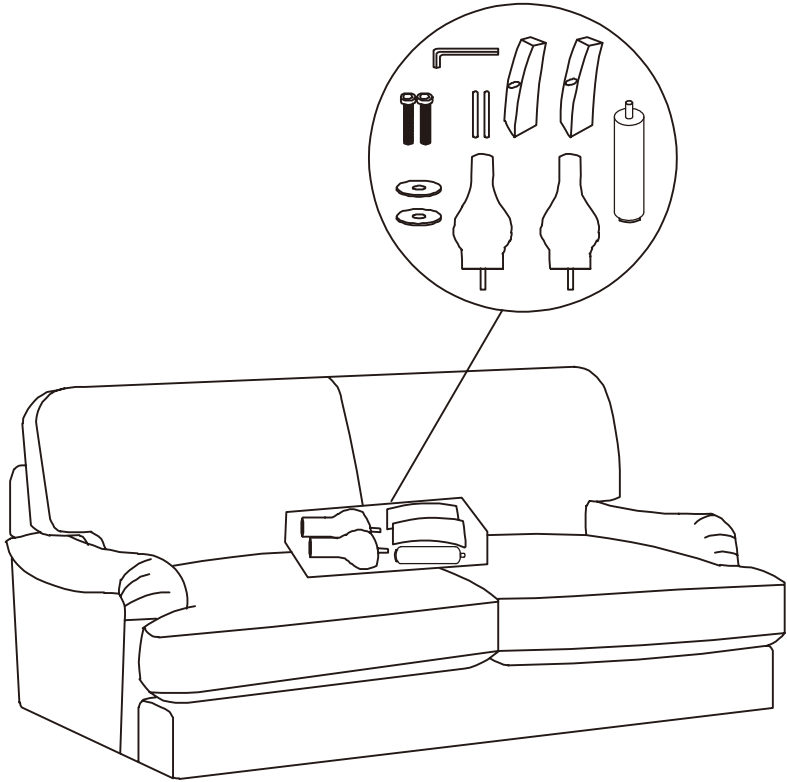

Step 2 Fasten the front legs, medium foot and affix the rear legs as shown in the above diagram using the bolts supplied.

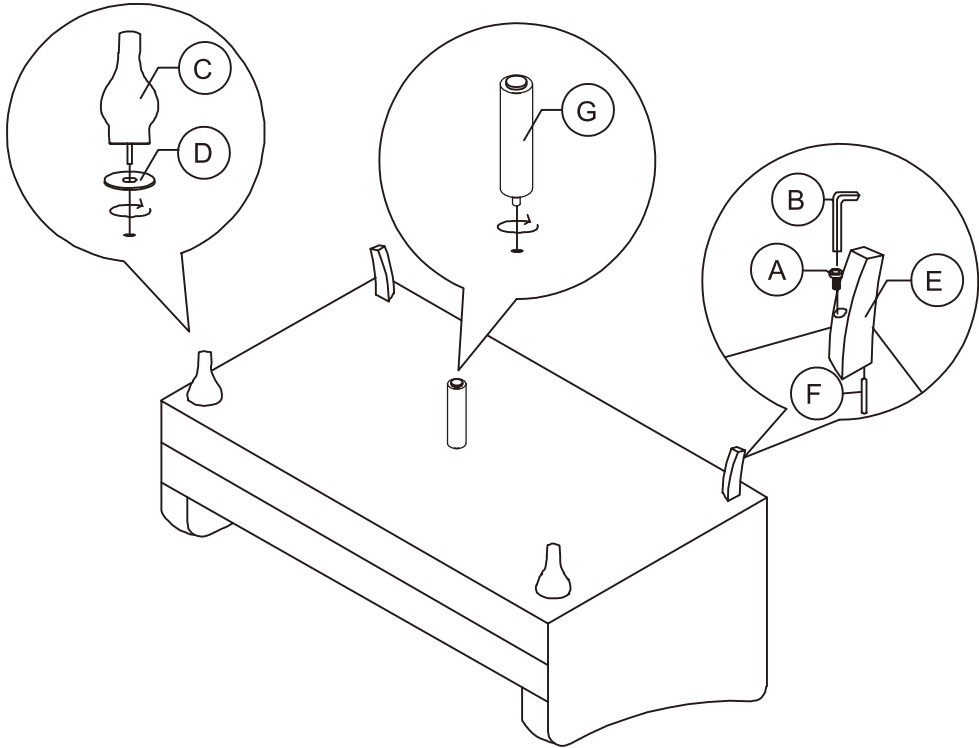

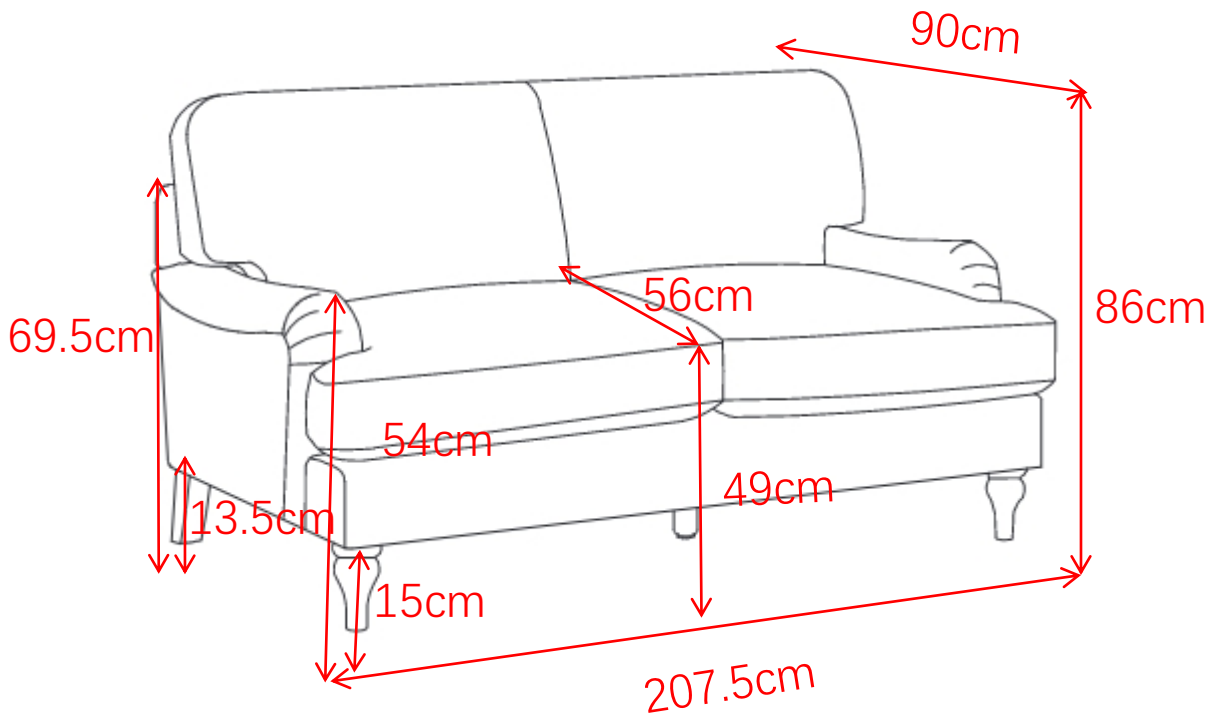

IMPORTANT

ASSEMBLY TIP

Before you begin, it's best to identify all of the parts and fittings to build your sofa frame. We advise laying these out on the floor to check you have everything, and to familiarise yourself with all of the parts and fittings before building.

TOP TIP

We recommend that you assemble the sofa in the room you'd like it to be located. This will help prevent any risk of damage to the frame whilst moving it.

SAFETY AND CARE

It's important to ensure children and animals are kept away from the assembly area, as there are small components used in this product which could present a choking hazard. All plastic and wrapping materials should also be kept away from children and animals to prevent any risk of suffocation.

HELP AND SUPPORT

Please contact our customer service team on 0113 519 0311 if you have any questions or issues with your purchase.

RECYCLING

Please ensure that packaging is disposed of in a safe and environmentally friendly way, and recycle where possible. Please keep your assembly instructions safe to refer back to in the future.

CARE AND MAINTENANCE

- 1.Clean with your vacuum curtain attachment (the one with a lint-catching fabric strip) or a lint roller to stop dust build up. Do this regularly to keep the sofa in its best condition.
- 2.Regularly plump the backrest pillows by shaking and squeezing to even out the filling.
- 3.Try to keep your sofa away from direct sunlight, and not too close to heat sources, as this can cause fading over time. Do not allow the sofa to make direct contact with any radiators or sources of heat.
- 4.Wipe up the spillages as quickly as possible by gently dabbing or blotting with a dry cloth until the mark fades away. Some tougher spills, such as oil and grease, can be more persistent and leave a stain. In this case, it's best to contact a specialist cleaning service.
- 5.Do not drag the sofa. When moving, lift the sofa off the floor.
- 6.Keep children and pets away from the assembly area and any packaging, small parts could choke is swallowed.
- 7.Do not sit on the arms of the sofa.
- 8.Do not jump on the sofa.
- 9.Only use the sofa on a flat and level surface.
- 10.Dispose of all packaging carefully and responsibly - recycle where possible.
- 11.Avoid sharp items such as toys, jean rivets, buckles etc

Leather Care

- Leather is a natural product and can display natural characteristics such as healed scars, uneven grain and creases. These are natural features, not faults.
- Leather upholstery is not suitable for conservatories or areas of intense sunlight.
- Overtime leather ages and colour change may be visible in areas of most use. Switch cushions and turn regularly to spread use and minimise this.
- **DO** wipe with a soft dry cloth weekly to remove any dust and debris.
- **DO** use a leather conditioner to help maintain the leather.
- **DO** use specialist leather cleaners if necessary and always follow the manufacturer's instructions. Spot test on a hidden area such as the back or underside of the product before using. We recommend using a professional cleaning service in situ for the best results.
- **DO NOT** use detergent cleaners or cleaning products not designed for leather.
- **DO NOT** vacuum leather or clean with water as this can cause permanent scratches or stains.
- **DO NOT** place direct heat sources near or onto the leather as this can cause surface appearance changes.

Faux Leather Care





- Faux leathers can naturally age like natural leather, causing colour change in areas of most use. Switch cushions and turn regularly to spread use and minimise this.
- **NEVER** use leather or upholstery cleaners, unless designed for faux leathers. Always spot test on a hidden area such as the back or underside of the product before using.

Pile or looped fabric care

- These are specialist fabrics and require gentle care.
- Avoiding getting piled fabrics wet. Velvet can get water stains.
- Some pile loss is natural.
- The surface of these fabrics can flatten or lift with use.
- Velvet and faux fur have a directional pile, resulting in colour and appearance change if direction and light is different. This is a natural characteristic.
- Velvet can appear creased/ crushed when first unpackaged or with use. Minimise by brushing with a soft brush and smoothing the fabric regularly. For extreme cases, restore the pile using steam, but always consult a professional first.
- We recommend brushing piled or looped fabrics every 1-2 weeks to maintain the appearance and cleanliness of faux fur. Always use a soft brush and avoid harsh brushing.
- Pay particular attention to heavily used areas, such as seat cushions, on faux fur products as the longer pile may mat with standard use if not brushed regularly.
- **DO** rotate cushion positions to allow the pile to recover and avoid matted.
- **DO** spot clean using water only.
- **DO** brush the pile regularly with a soft brush to help prevent the pile matting. Brushing will also remove any dirt and debris caught in the pile.
- **DO** use a vacuum to help remove dirt and debris from within the pile.
- **DO** always brush following the direction of the pile.
- **DO** allow to air dry naturally.
- **DO NOT** brush boucle fabric as this may pull the looped yarns causing damage.
- **DO NOT** rub or use heat to dry piled fabrics as this can mat and melt the fibres.
- **DO NOT** use household fabric conditioners or harsh chemicals as this can damage or mat the pile.

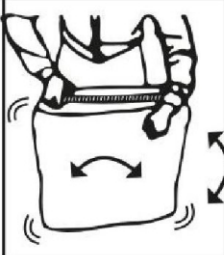

Fibre Filled Cushions

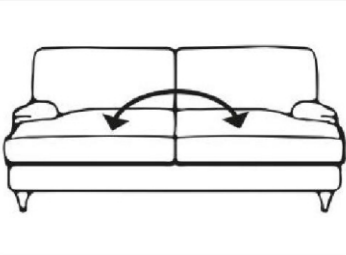
Cushions containing loose fibres require vigorous plumping, shaking and teasing daily. This will add air back into the fibres and prevent the cushion from going flat and/or developing lumps caused by the fibres matting together with use which is irreversible damage.

					
1. Hold the zip	2. Shake vigorously	3. Tease the fibre	4. Plump the fibres	5. Turn the cushion	6. If removable, switch cushion positions to even out wear

Foam Filled Cushions

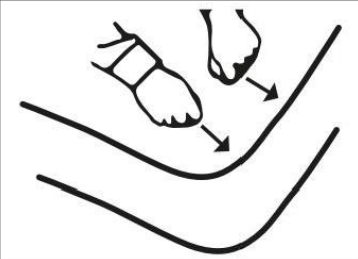
Cushions made from foam do not require the same level of daily plumping as fibre filled cushions, however they do require regular neatening, turning and switching of cushion positions to prolong their life and even out wear.

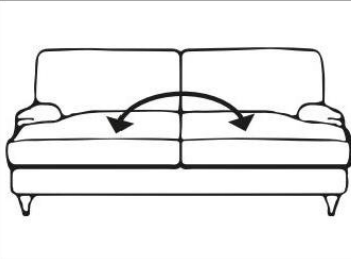
		
1. Ensure the cushion seams are aligned	2. Turn the cushion	3. If removable, switch cushion positions to even out wear

Guarantee.

10
YEAR

This product is covered by a Guarantee.

Any accidental damage caused by misuse are not covered.

The Guarantee is valid from the date of purchase. Please keep your proof of purchase as we will need to see this to validate your guarantee.

This Guarantee applies only when the product has been used for domestic use only within England, Scotland, Wales, Northern Ireland and Jersey.

For further information, please see our Guarantee T&C document on the product page on **Dunelm.com** or contact our customer service team.