

Assembly Instructions

Size: W63*D63*H76 cm

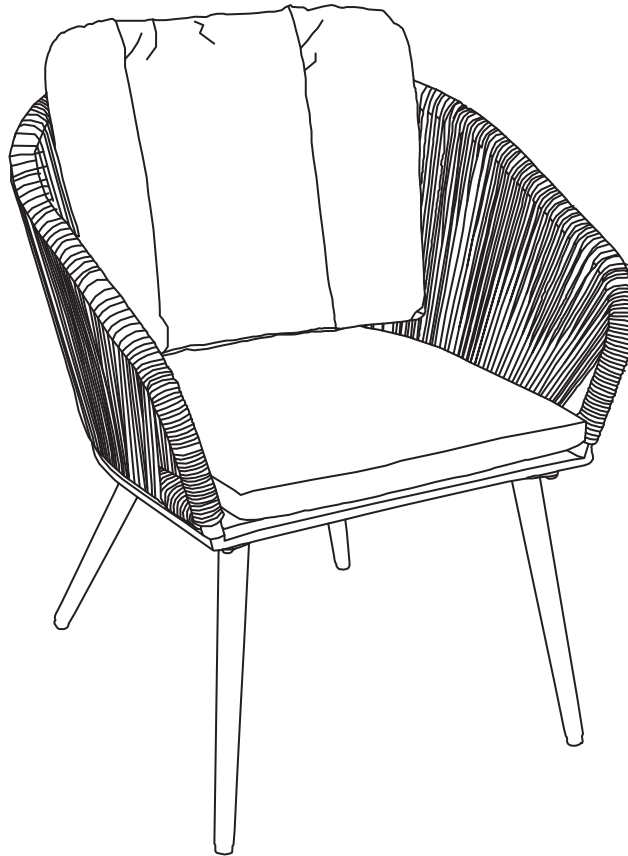

**Furniture should be covered/stored whilst not in use to prolong its longevity.
(It should also be covered in adverse weather.)**

This product is for Domestic Use only!
IMPORTANT, RETAIN FOR FUTURE REFERENCE
READ CAREFULLY

Before you start



Warnings

IMPORTANT, RETAIN FOR FUTURE REFERENCE READ CAREFULLY

See enclosed instructions for assembly, safety and care information.

Failure to follow the warnings could result in serious injury.

Handle heavy parts with care.

Ensure that this product is fully assembled as illustrated before use.

This product should only be used on firm, level ground.

Keep small parts out of reach of children.

Do not stand or climb onto this product.

This product is intended for **domestic use** only.

Ensure the product is always placed on level ground.

Furniture can be dangerous if incorrectly used. No liability will be accepted for damage or injury caused by incorrect use of this product.



Dos

When you are ready to start, make sure that you have the right tools, plenty of space and a clean, dry area for assembly.

Unwrap all packaging materials and place the components on suitable surface to prevent scratching your product.

Check the pack and make sure you have all parts listed. In the event of problems or missing parts, please contact the seller.

Check all screws and bolts are tightened and inspect regularly. We recommend the use of furniture covers to protect your product when not in use.

This product is suitable for all year outdoor use, but we recommend that a furniture cover be used to add additional protection to your product when not in use.

PLEASE NOTE - All cushions should be stored indoors after use. The cushions are not waterproof.

During severe weather conditions and in the winter months we recommend moving your furniture inside into a cool, dry place.

Before storage, ensure that the product is clean and dry.

To clean, wipe down with a sponge and warm soapy water and

wipe with a clean, dry cloth.



Don'ts

Never tilt the chair during use.

Do not stand or climb onto the product.

Do not use power tools to construct this product.

Do not sit or lean onto the rims of this product.

Do not use this product if parts are missing, damaged or worn.

Never use scourers, abrasives or chemical cleaner.

Do not use this product as a ladder as this could lead to the product becoming unbalanced and overturning.

Never drag furniture when moving it, always lift it.

Number of people required for assembly

One person



Time to assemble

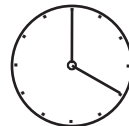

20 minutes

Tools required



Tips:







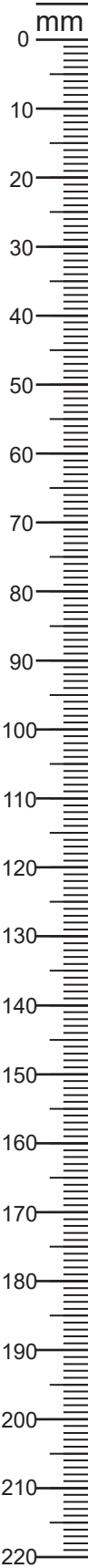

It is best not to fully tighten the nuts and bolts until they are all correctly located. Only carefully tighten them when you are satisfied with the alignment of all components.

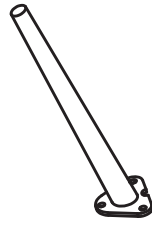
Be careful not to overtighten.

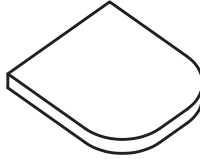
Components, fixtures & fittings (not actual size)

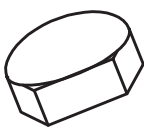

Parts List

Part No.	Diagram	Qty.	Part No.	Diagram	Qty.
A	 Seat	4 PCS	B	 Front Leg	8 PCS
C	 Rear Leg	8 PCS	D	 Seat Cushion	4 PCS
E	 Backrest Cushion	4 PCS	F1	 Bolt Head Cap	48 PCS
W25	 M6*25mm Bolt	48 PCS	S	 Spanner	1 PC
F3	 Flat Washer	48 PCS	F2	 Spring Washer	48 PCS

Please note the diagram is for reference only, it may not fully represent the actual appearance of the parts.

Step by step assembly instructions

Step One

Place the Seat (A) upside down onto a soft surface to avoid the scratches. Attach the Front Legs (B) and Rear Legs (C) onto the bottom of the Seat (A) using Flat Washers (F3), Spring Washers (F2) and Bolts (W25).

Once you are satisfied with the alignment of all components, carefully tighten all bolts using Spanner (S).

Cover each Bolt Head with Bolt Head Cap (F1).

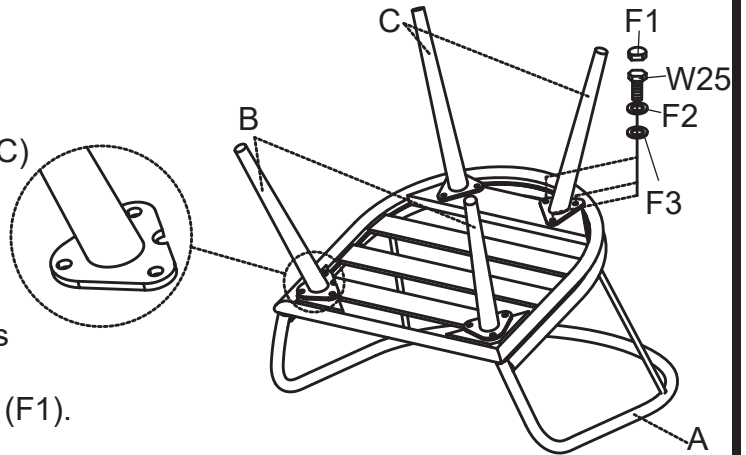

Step Two

Stand the Chair in the upright position. Place the Seat Cushion (D) and Backrest Cushion (E) onto the chair Seat. Level the chair with Adjustable Feet Screw. Your Chair is now ready for use.

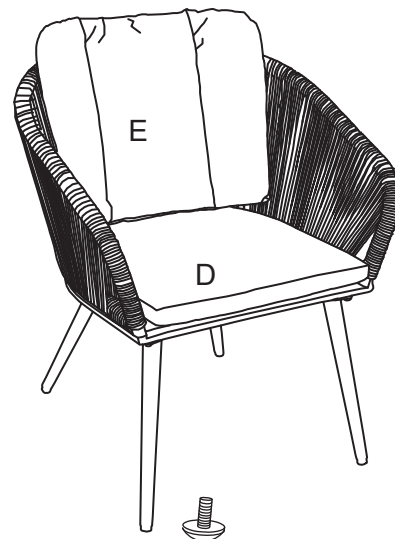

Adjustable Feet Screw

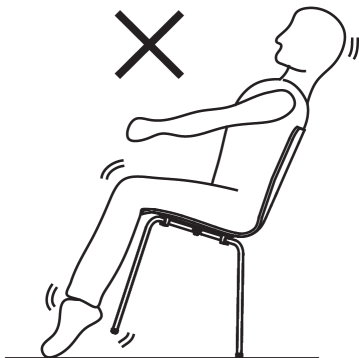

Never tilt the Chair during use. Ensure the product is always placed firmly on the ground.

PLEASE KEEP THESE INSTRUCTIONS FOR FUTURE REFERENCE