

DUSK.COM

LIVING | BEDROOM | DINING

Sally Barstool
Box Dimensions: W99xD53xH30 (cm)
Product Dimensions: W52xD54xH96 (cm)

Sally Barstool

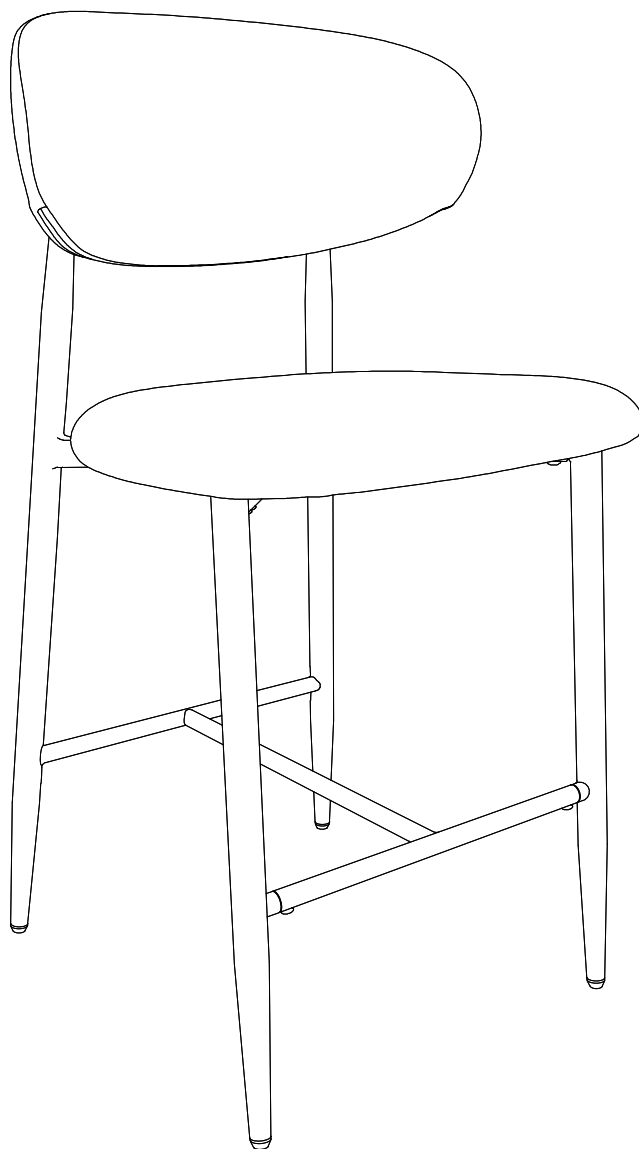

Up to 10 minutes
assembly time

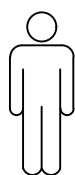

One person
assembly

V2.0





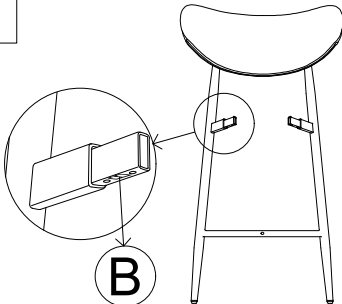
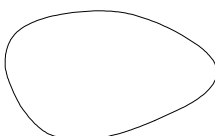
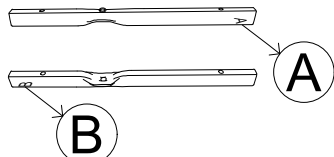
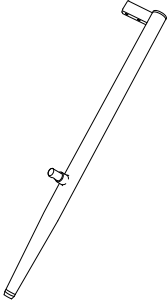
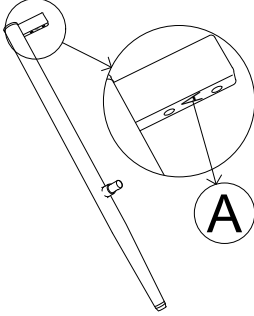
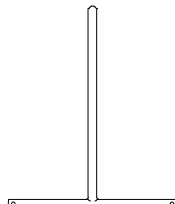

Page-1-5

Parts Check List

<div data-bbox="76 264 124 331" style="border: 1px solid black; padding: 2px; display: inline-block;">1</div> 	<div data-bbox="561 264 609 331" style="border: 1px solid black; padding: 2px; display: inline-block;">2</div> 	<div data-bbox="1056 264 1104 331" style="border: 1px solid black; padding: 2px; display: inline-block;">3</div> 
Back	Seat	Medium
1pc	1pc	2pcs
<div data-bbox="76 766 124 833" style="border: 1px solid black; padding: 2px; display: inline-block;">4</div> 	<div data-bbox="561 766 609 833" style="border: 1px solid black; padding: 2px; display: inline-block;">5</div> 	<div data-bbox="1056 766 1104 833" style="border: 1px solid black; padding: 2px; display: inline-block;">6</div> 
Leg	Leg	Foot rest
1pc	1pc	1pc

Fittings Check List

please check you have all the fittings listed below with you product

<div data-bbox="67 1438 124 1505" style="border: 1px solid black; padding: 2px; display: inline-block;">A</div> 	<div data-bbox="561 1438 619 1505" style="border: 1px solid black; padding: 2px; display: inline-block;">B</div> 	<div data-bbox="1056 1438 1114 1505" style="border: 1px solid black; padding: 2px; display: inline-block;">C</div> 
M6*30MM	M6*12MM	M6*30MM
1pc+1pc extra	10pcs+1pc extra	1pc+1pc extra
<div data-bbox="67 1774 124 1841" style="border: 1px solid black; padding: 2px; display: inline-block;">D</div> 	<div data-bbox="561 1774 619 1841" style="border: 1px solid black; padding: 2px; display: inline-block;">E</div> 	<div data-bbox="1056 1774 1114 1841" style="border: 1px solid black; padding: 2px; display: inline-block;">F</div> 
M6*45MM	M6	Foot cap
4pcs+1pc extra	1pc	2pcs extra

Step 1: Put the seat (2) underneath, then connecting the leg (1) and the medium (3) . Remember do not tighten fully until the structure is assembled.

A  1pc

E  1pc

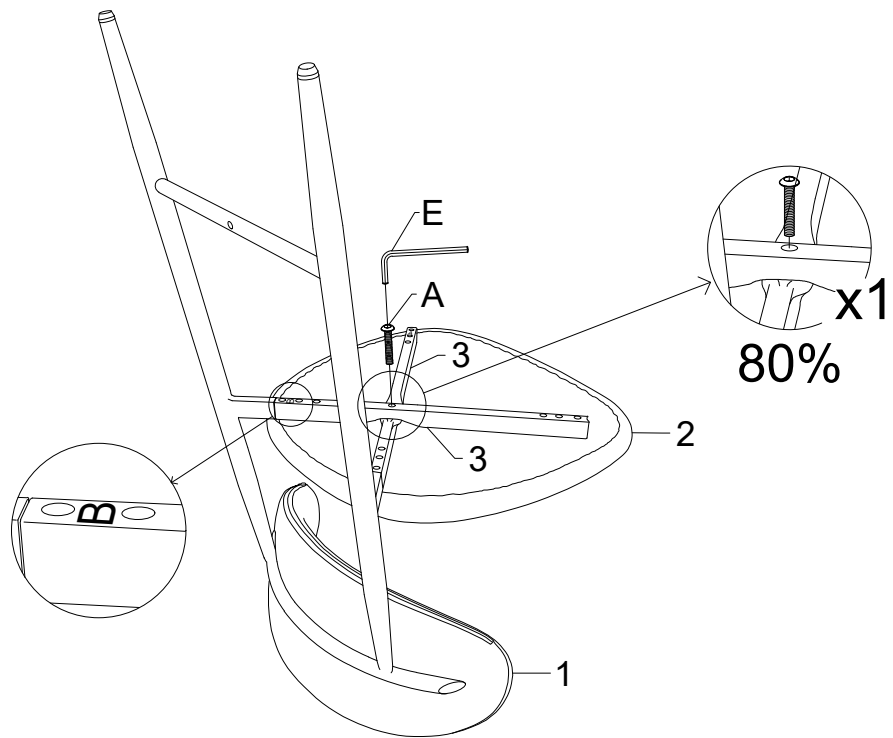

80%

Step 2: Attach the leg (4) and the leg (5) to the assembled medium.

B  8pcs

D  4pcs

E  1pc

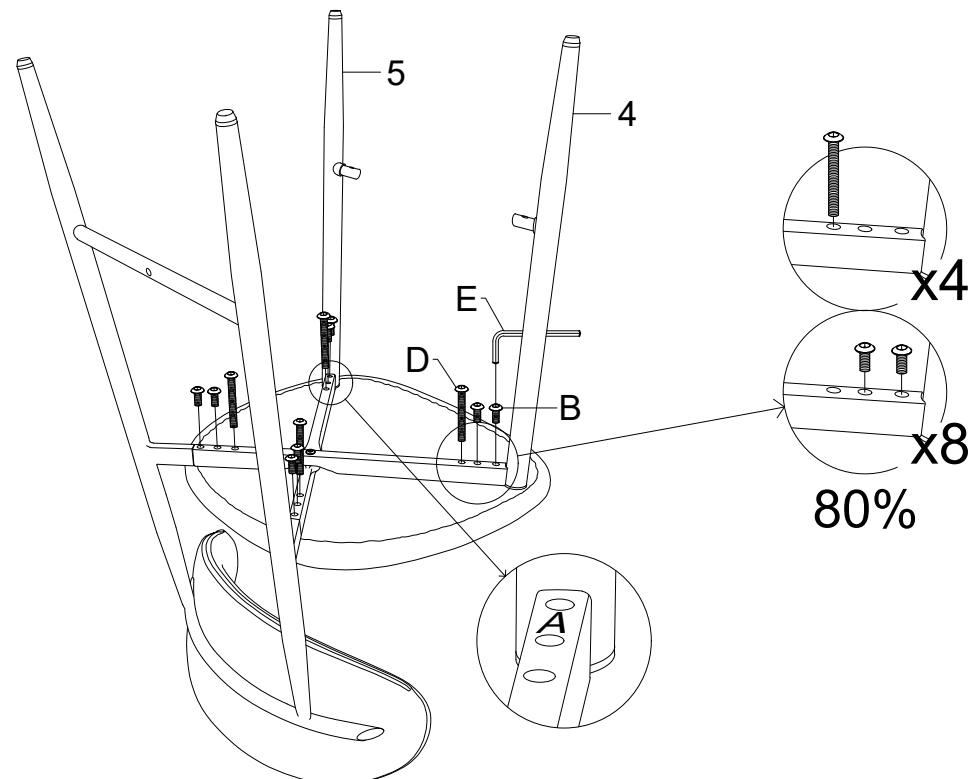

80%

Step 3: Attach the foot rest (6) to the assembled frame.

B  2pcs

C  1pc

E  1pc

Pull the legs of the chair apart a bit towards the outside and put in the footrest crossbar.

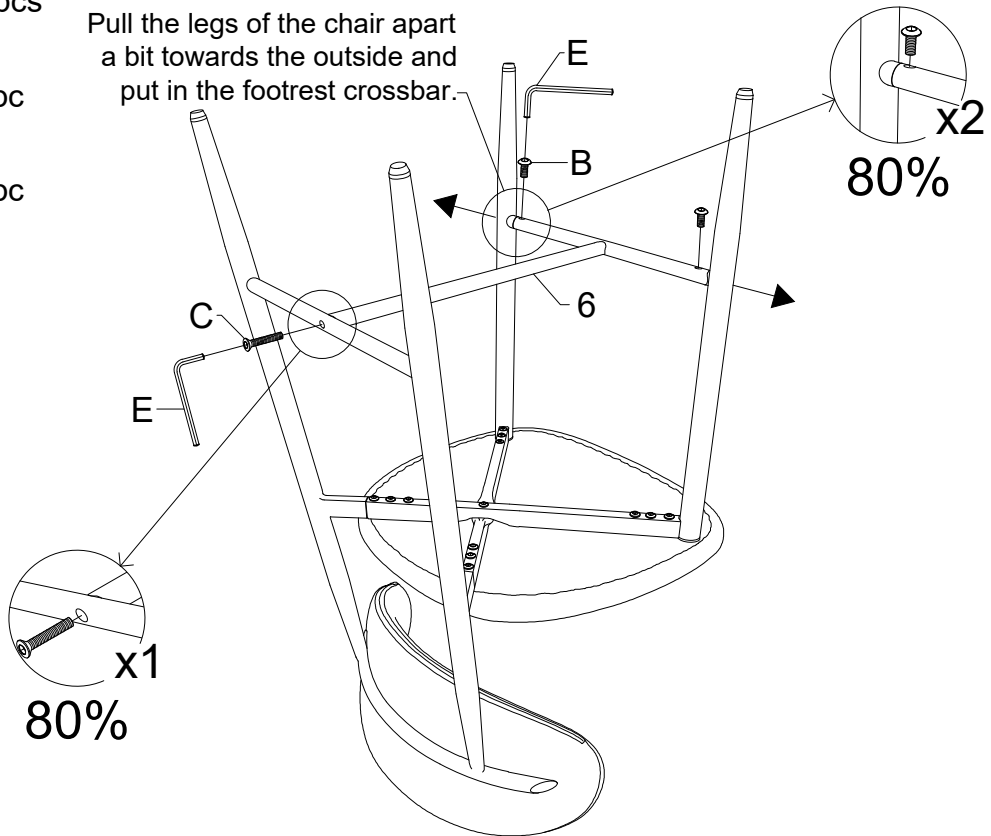

Step 4: Put the assembled chair onto a flat base and then fully tighten all bolts.

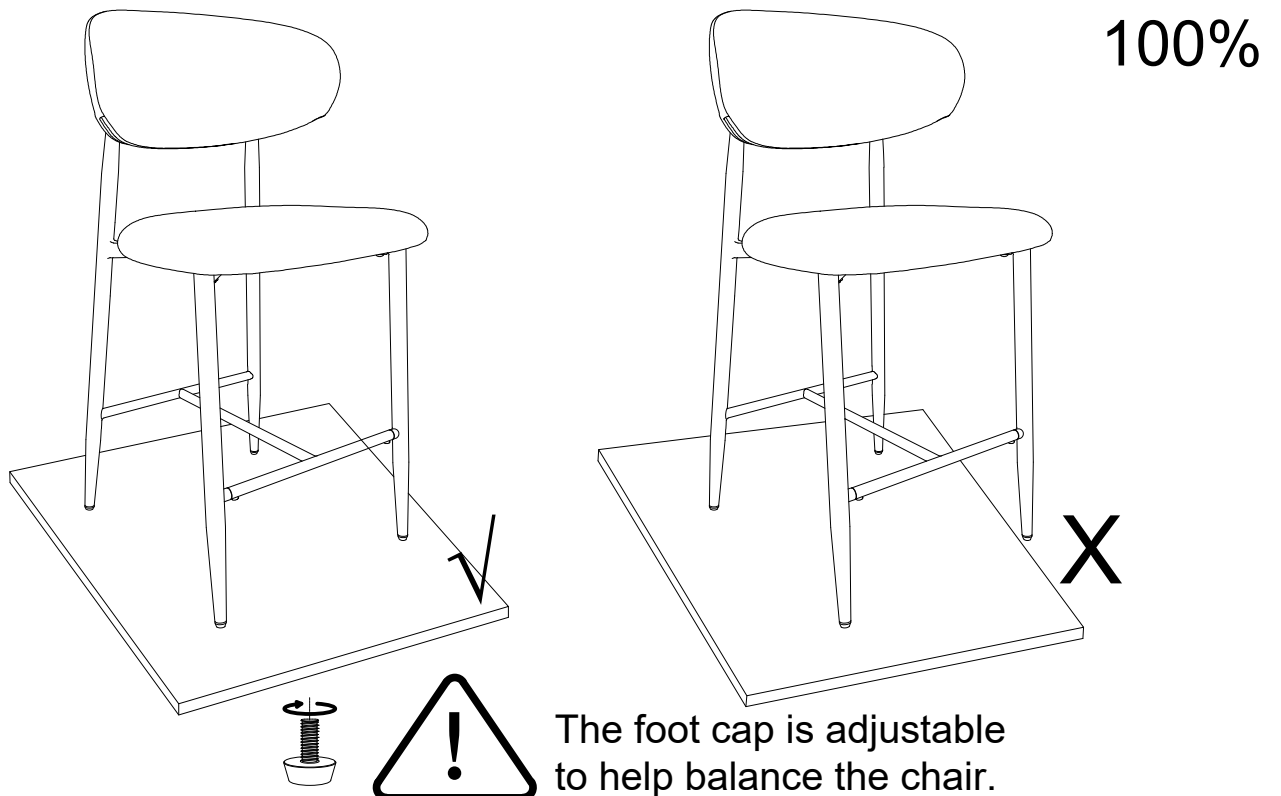

Care and Maintenance

- 1.Clean with your vacuum curtain attachment (the one with a lint-catching fabric strip) or a lint roller to stop dust build up.Do this regularly to keep the chair in its best condition.
- 2.Try to keep your chair away from direct sunlight, and not too close to heat sources, as this can cause fading over time.Do not allow the chair to make direct contact with any radiators or sources of heat.
- 3.Wipe up the spillages as quickly as possible by gently dabbing or blotting with a dry cloth until the mark fades away. Some tougher spills, such as oil and grease,can be more persistent and leave a stain. In this case, it's best to contact a specialist cleaning service.
- 4.Do not drag the chair. When moving, lift the chair off the floor.
- 5.Keep children and pets away while assembling the chair. Small parts could be a choking hazard.
- 6.Re-tighten all nuts and bolts after two weeks of use and regularly thereafter.
- 7.Do not sit on the arms of the chair.
- 8.Do not jump on the chair.
- 9.Only use the chair on a flat and level surface.
- 10.Dispose of all packaging carefully and responsibly - recycle where possible.
- 11.This product is intended for domestic use only, not commercial purposes.

Important

Assembly Tip

Before you begin, it's best to identify all of the parts and fittings to build your chair.

We advise laying these out on the floor to check you have everything, and to familiarise your-self with all of the parts and fittings before building.

Top Tip

We recommend that you build your new chair in the room you'd like it to be located. This will help prevent any risk of damage to the frame whilst moving it.

Safety and Care

It's important to ensure children and animals are kept away from the assembly area.As there are small components used in this product which could present a choking hazard.All plastic and wrapping materials should also be kept away from children and animals to prevent any risk of suffocation.

Help and Support

Please contact our customer service team on 0113 519 0311 if you have any questions or issues with your purchase.

Recycling

Please ensure that packaging is disposed of in a safe and environmentally friendly way, and recycle where possible.Please keep your assembly instructions safe to refer back to in the future.